

驱动系统/Drive system						
序号/NO	编码/SN	Name	名称	数量/QTY	备注/Remarks	
1	255013510001	Drive axle(DW)	驱动桥 (DW)	1	FE4P30N	
1	256113510001	Drive axle(DW-3.5T)	驱动桥 (DW-3.5T)	1	FE4P35N	
2	255013520003	Adjusting shim 1	调整垫片1	1		
3	255013520002	Nut M20x1.5	螺母M20x1.5	8		
4	910600100021	Dowel pin GB119.2-8x25	圆柱销GB119.2-8x25	1		
5	910400100007	Washer GB97.1-10-200HV	平垫圈GB97.1-10-200HV	12		
6	910400500007	Washer GB93-10	弹簧垫圈GB93-10	12		
7	910100400004	Bolt GB5786-M10x1.25x30-8.8	螺栓GB5786-M10x1.25x30-8.8	12		
8	910300900002	Nut GB6178-M20-8	螺母GB6178-M20-8	1		
9	910400100009	Washer GB97.1-14-200HV	平垫圈GB97.1-14-200HV	5		
10	910400500009	Washer GB93-14	弹簧垫圈GB93-14	5		
11	910100200010	Bolt GB5785-M14x1.5x50-8.8	螺栓GB5785-M14x1.5x50-8.8	5		
12	910600600037	Split pin GB91-4x40	开口销GB91-4x40	1		
13	910400500012	Washer GB93-20	弹簧垫圈GB93-20	9		
14	910400100012	Washer GB97.1-20-200HV	平垫圈GB97.1-20-200HV	1		
15	910100500006	BoltGB31.1-M20x90-8.8	螺栓GB31.1-M20x90-8.8	1		
16	910800100020	O ring 90x2.65	O形圈-内90x2.65	1		
17	920900100024	Motor (HP)	电机 (HP)	1	选装/Optional	
17	920900100055	Motor (WN)	电机 (WN)	1	选装/Optional	
18	255014010002	Gear box (ZN)	变速箱 (ZN)	1		
19	255013520005	Seal washer	密封垫	1		
20	255013520001	Bolt M20x1.5x66	螺栓M20x1.5x66	8		
21	255013520004	Adjusting washer 2	调整垫片2	2		
22	255098513251	Encoder (HP)	编码器 (HP)	1	选装/Optional	
22	255098513253	Encoder (WN)	编码器 (WN)	1	选装/Optional	

驱动桥(DW)/Drive axle(DW)

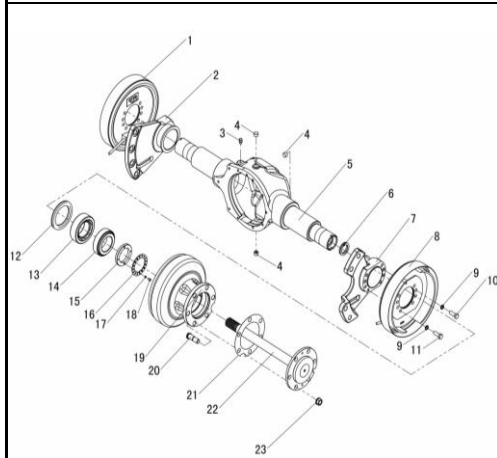

序号/NO	编码/SN	Name	名称	数量/QTY	备注/Remarks
1	255098513501	Left brake assembly	左制动器总成	1	
2	255098523502	Drive axle left bearing plate	驱动桥左支承板	1	
3	255098523503	Air hole assembly	通气孔总成	1	
4	255098523504	Blocking	堵塞	1	
5	255098523505	New drive axle housing	新驱动桥壳	1	FE4P30N
5	256198523505	New drive axle housing	新驱动桥壳(3.5T)	1	FE4P35N
6	255098523506	Oil seal	油封	2	
7	255098523507	Drive axle right bearing plate	驱动桥右支承板	1	
8	255098513508	Right brake assembly	右制动器总成	1	
9	255098523509	Spring washer 14	弹簧14	16	
10	255098523510	Brake bolt	制动器螺栓	4	
11	255098523511	Brake bolt	制动器螺栓	12	
12	255098523512	Oil seal SD100x140x12	油封	2	
13	255098023513	Bearing 30615	轴承	2	
14	255098523514	Bearing331151	轴承	2	
15	255098523515	Nut seat	螺母座	2	
16	255098523516	Nut seat circlip	螺母座挡圈	2	
17	255098523517	Spring washer 6	弹簧6	4	
18	255098523518	Bolt M6x12-4.8	螺栓M6x12-4.8	4	
19	255098523519	Hub	轮毂	2	
20	255098523520	Hub connecting bolt	轮毂连接螺栓	12	
21	255098523521	Half shaft seal washer	半轴(新)密封垫	1	
22	255098523522	Half shaft	半轴	1	
23	255098523523	Rim nut	轮毂螺母	12	

制动器总成(DW)/Brake assembly (DW)

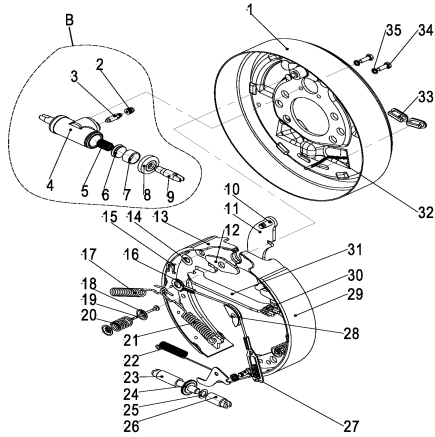

序号/NO	编码/SN	Name	名称	数量/QTY	备注/Remark
1	▲	Back plate assy	左制动器底板	2	
1	▲	R.H.back plate	右制动器底板	1	
B	255098513505	Wheel cylinder assy	制动器分泵总成	2	
2	▲	Hood,drain screw	分泵放气螺钉罩	2	
3	▲	Screw,vent	分泵放气螺钉	2	
4	▲	Cylinder body	制动分泵缸体	2	
5	▲	Spring	分泵弹簧	2	
6	▲	Cup	分泵皮碗	2	
7	▲	Piston	分泵活塞	2	
8	▲	Support hood	分泵护罩	2	
9	▲	Rod,piston	分泵活塞顶杆	2	
10	▲	Pin	销钉	2	
11	▲	Pull rod	手制动拉杆	2	
12	▲	Heel block	垫块	2	
13	255098513509	Brake shoe & friction piece	制动蹄带摩擦片总成(前)	2	
14	▲	Washer	垫圈	2	
15	▲	Clip reed	卡簧	1	
16	▲	Wire unit,spring	弹簧线装置	2	
17	▲	Release spring	制动蹄左回位弹簧	2	
18	▲	Washer	垫圈	2	
19	▲	Seat,spring	弹簧座	2	
20	▲	Spring	弹簧	2	
21	▲	Return spring	制动蹄右回位弹簧	2	
22	▲	Spring	弹簧	2	
23	▲	Clearance adjuster	间隙调整器	2	
24	▲	pinion	小齿轮	2	
25	▲	Washer	垫圈	2	
26	▲	Adjust the stud	调整螺栓	2	
27	▲	pin	定位销	2	
28	▲	Guide block	导向块	2	
29	255098513510	Brake shoe & friction piece	制动蹄带摩擦片总成(后)	2	
30	▲	Protective sleeve	保护套	4	
31	▲	poles	支撑杆	4	
32	255098513503	Cable,R.H.	制动钢索总成(右)	1	
32	255098513504	Cable,L.H.	制动钢索总成(左)	1	
33	▲	Plug,rubber	保护套	2	
34	▲	Spring washer	弹簧垫圈	2	
35	▲	Bolt	螺栓	2	

255014010002 变速箱(ZN)/Gear box(ZN)

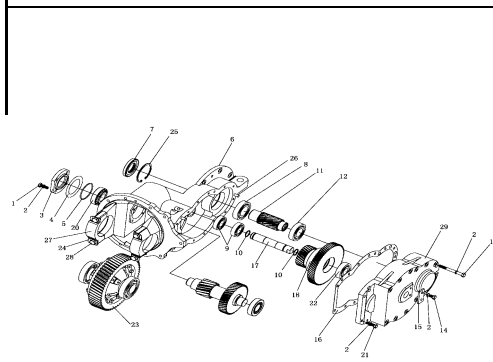

序号/NO	编码/SN	Name	名称	数量/QTY	备注/Remark
1	910100300036	Bolt	螺栓M10X25	4	
2	910400500007	Spring washer	弹簧垫圈10	20	
3	255098524003	Bearing cap	轴承盖	1	
4	255098524004	Spacer	垫片	4	
5	910800100032	O seal ring	O形密封圈75X3.1	1	
6	255098524006	Box	箱体	1	
7	255098524007	Oil seal	油封TC45X85X10	1	
8	910700200024	Bearing6209	深沟球轴承6209	1	
9	910700200021	Bearing6206	深沟球轴承6206	3	
10	255098524010	O-ring	O形密封圈25X2.65	2	
11	255098524011	Input shaft assembly	输入轴组件	1	
12	910700200023	Bearing6208	深沟球轴承6208	1	
13	910100100125	Bolt M10X100	螺栓M10X100	12	
14	910100300034	Bolt M10X16	螺栓M10X16	2	
15	255098524017	Stop dog	挡块	1	
16	255098524019	Paper pad	纸垫	1	
17	255098524020	axle	轴	1	
18	255098524021	Gear	双联齿轮	1	
19	255098524022	Gear assembly	齿轴组件	1	
20	255098524023	Bearing32207	圆锥滚子轴承32207	2	
21	910100300038	Bolt M10X35	螺栓M10X35	2	
22	255098524042	Bearing 6306	深沟球轴承6306	1	
23	255098524043	Differential assembly	差速器总成	1	
24	255098524027	Locking plate	锁片	4	
25	255098524044	Hole with elastic retainer 85	孔用弹性挡圈85	1	
26	910600100013	Pin6X20	圆柱销6X20	2	
27	255098524025	Bearing seat	轴承座	2	
28	255098524026	Bolt	螺栓	4	
29	255098524018	Box cover	箱盖	1	

驱动轮总成/Drive wheel assembly

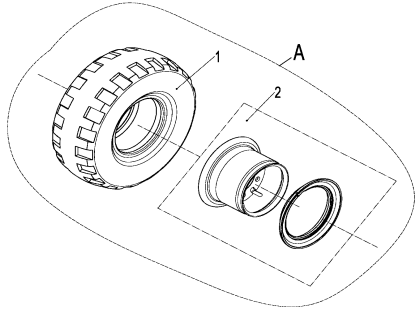

序号/NO	编码/SN	Name	名称	数量/QTY	备注/Remarks
A	255013010010	Drive wheel assembly 23x9-10-18PR(gas)	驱动轮总成23x9-10-18PR(充气)	2	FE4P30N选装
	255013010011	Drive wheel assembly 23x9-10 (solid)	驱动轮总成23x9-10 (实心)	2	FE4P30N选装
	255013010012	Drive wheel assembly 23x9-10(environmental)	驱动轮总成23x9-10 (环保)	2	FE4P30N选装
A	256102013001	Drive wheel assembly 23x10-12 (solid)	驱动轮总成23x10-12(实心)	2	FE4P35N选装
	256102013002	Drive wheel assembly 23x10-12(environmental)	驱动轮总成23x10-12(环保)	2	FE4P35N选装
1	255013010002	Pneumatic tyre 23x9-10-18PR	充气轮胎23x9-10-18PR	2	FE4P30N选装
	255013010003	Solid tyre 23x9-10	实心轮胎23x9-10	2	FE4P30N选装
	255013010007	Environmental protection tyre 23x9-10	环保轮胎23x9-10	2	FE4P30N选装
1	256113011002	Solid tyre 23x10-12	轮胎23x10-12(实心)	2	FE4P35N选装
	256113011003	Environmental protection tyre 23x10-12	轮胎23x10-12(环保)	2	FE4P35N选装
2	255013010001	Rim assembly 6.50F	轮辋总成6.50F	2	FE4P30N选装
2	256113011001	Rim assembly 8.00G-12	轮辋总成8.00G-12	2	FE4P35N选装

蓄電池及托架/Battery and bracket					
序号/NO	編碼/SN	Name	名称	数量/QTY	备注/Remarks
1	256037010001	Battery (80V500Ah) (weld)	電池 (80V500Ah) (焊)	1	焊接式
	256037010005	Battery (80V560Ah) (weld)	電池 (80V560Ah) (焊)	1	焊接式
	256037010002	Battery (80V500Ah) (bolt)	電池 (80V500Ah) (螺)	1	螺栓式
	256037010006	Battery (80V560Ah) (bolt)	電池 (80V560Ah) (螺)	1	螺栓式
1	256137010001	Battery (80V500Ah) (weld)	電池 (80V500Ah) (焊)	1	3.5T側出专用
	256137010002	Battery (80V500Ah) (bolt)	電池 (80V500Ah) (螺)	1	3.5T側出专用
2	255012510001	Battery bracket welding	電池托架焊合	1	3.0T側出专用

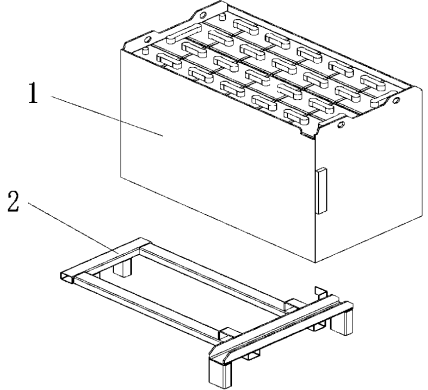

电瓶箱盖/Battery box cover

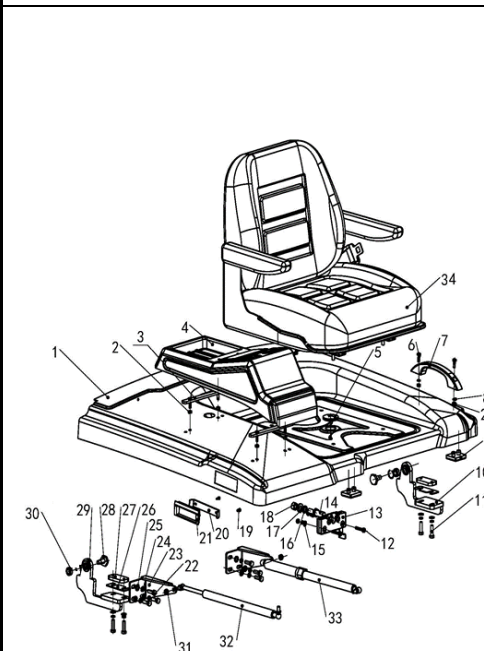

序号/NO	编码/SN	Name	名称	数量/QTY	备注/Remarks
1	256021010002	Batthey box cover welding	电瓶箱盖焊合	1	
2	910300100005	Nut GB6170-M6-10	螺母GB6170-M6-10	8	
3	255021010016	Pressing plate weiding	压板焊合	2	
4	255021020003	Trim	装饰盖	1	
5	255021020046	Guard cicle φ35	保护圈 φ 35	1	
6	910200500053	ScrewGB818-M6x20-4.8	螺钉GB818-M6x20-4.8	2	
7	255021020020	Handle	拉手	1	
8	910400500005	WasherGB93-6	弹簧垫圈GB93-6	4	
9	255021020068	Damping pad	缓冲垫	2	
10	255021010005	Hinge welding (left)	铰链焊合(左)	1	
11	910100300024	Bolt GB5783-M8x30-8.8	螺栓GB5783-M8x30-8.8	4	
12	910200500056	Screw GB818-M6x35-4.8	螺钉GB818-M6x35-4.8	2	
13	255021010010	Head cover lock	顶盖锁	1	
14	255021020052	Lock tongue 2	锁舌2	1	
15	910400100005	Washer GB97.1-6-200HV	平垫圈GB97.1-6-200HV	2	
16	910400500008	WasherGB93-12	弹簧垫圈GB93-12	1	
17	910400100008	WasherGB97.1-12-200HV	平垫圈GB97.1-12-200HV	1	
18	910300100008	Nut GB6170-M12-10	螺母GB6170-M12-10	1	
19	910200500021	Screw GB818-M4x10-4.8	螺钉GB818-M4x10-4.8	2	
20	255021020055	Fixing plate	固定板	1	
21	255021020021	Handle(inside)	拉手(内)	1	
22	910100300023	Bolt GB5783-M8x25-8.8	螺栓GB5783-M8x25-8.8	6	
23	255021020047	Holder	支架	2	
24	910400500006	Washer GB93-8	弹簧垫圈GB93-8	10	
25	910400100006	Washer GB97.1-8-200HV	平垫圈GB97.1-8-200HV	10	
26	255021020054	Adjusting pad	调整垫	2	
27	255021020045	Bed plate	座板	2	
28	255021020043	Bolt	固定螺栓	2	
29	255021010006	Hinge welding (right)	铰链焊合(右)	1	
30	255021010014	BearingGE12E	关节轴承GE12E	2	
31	910300100006	NutGB6170-M8-10	螺母GB6170-M8-10	2	
32	940400100027	Air spring 350N(D620)	气弹簧350N(D620)	1	
33	940400100031	Air spring500N(D620)	气弹簧500N(D620)-自锁	1	
34	255037510001	Seat (STD.)	座椅(标配)	1	标配/STD.
	255037510003	Seat (Comfortable)	座椅(舒适型)	1	选装/Optional
	255037510004	Seat (Vibratio)	座椅(减振型)	1	选装/Optional

右侧门(侧出式)/Right side door

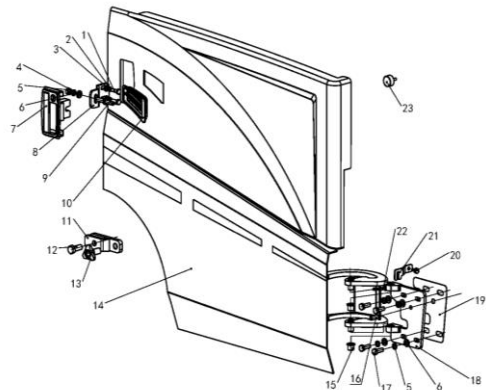

序号/NO	编码/SN	Name	名称	数量/QTY	备注/Remarks
1	910100300023	Bolt GB5783-M8x25-8.8	螺栓GB5783-M8x25-8.8	2	
2	910400500006	Washer GB93-8	弹簧垫圈GB93-8	2	
3	910400100006	Washer GB97.1-8-200HV	平垫圈GB97.1-8-200HV	2	
4	910300100007	Nut GB6170-M10-10	螺母GB6170-M10-10	1	
5	910400500007	Washer GB93-10	弹簧垫圈GB93-10	5	
6	910400100007	Washer GB97.1-10-200HV	平垫圈GB97.1-10-200HV	5	
7	255021010009	Side door lock	侧门锁	1	
8	255021020039	Fixing plate	固定板	1	
9	255021020040	Lock tongue 1	锁舌1	1	
10	505621520041	Air hole (left)	通风孔(左)	1	
11	255021010007	Limit seat welding	限位座焊接	1	
12	910100300063	Bolt GB5783-M14x35-8.8	螺栓GB5783-M14x35-8.8	2	
13	255021020059	Star shaped handle	星形把手	1	
14	256021010001	Side door welding (right)	侧门焊接(右)	1	
15	940500200016	Bushing 16x18x16-SF-1	复合套(肩)16x18x16-SF-1	2	
16	910600100031	Dowel pin GB119.2-10x30	圆柱销GB119.2-10x30	1	
17	910100300037	Bolt GB5783-M10x30-8.8	螺栓GB5783-M10x30-8.8	4	
18	255021010004	Hinge seat welding	铰链座焊接	1	
19	255021020044	Adjusting washer	调整垫	1	
20	255021020042	Bolt	螺栓	1	
21	255021020041	Limit plate	限位板	1	
22	910100300014	Bolt GB5783-M6x35-8.8	螺栓GB5783-M6x35-8.8	1	
23	505618020016	Damping pad	缓冲垫	2	

转向装置及安装/Steering mechanism and installatio

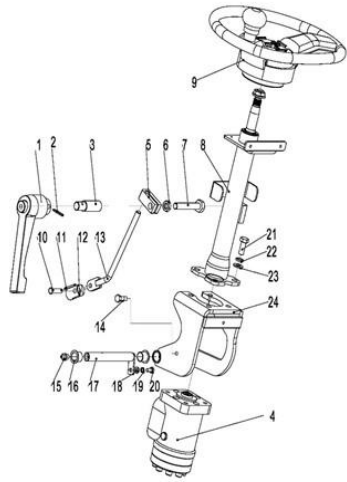

序号/NO	编码/SN	Name	名称	数量/QTY	备注/Remarks
1	255015010007	Adjustable handle	可调手柄	1	
2	910600400015	Dowel pin GB879.1-4x30	弹性圆柱销GB879.1-4x30	1	
3	255015020025	Packing set	锁紧套	1	
4	255015010002	Steering gear	转向器	1	
5	255015020019	Latch segment	锁紧块	1	
6	910300300006	Nut GB6172.1-M12-05	螺母GB6172.1-M12-05	1	
7	910100300057	Bolt GB5783-M12x70-8.8	螺栓GB5783-M12x70-8.8	1	
8	255015010001	Steering column	转向管柱总成	1	
9	255015010003	Steering wheel	方向盘	1	
10	910600700014	Short axle GB882-6x26x1.6	销轴GB882-6x26x1.6	1	
11	910600600005	Split pin GB91-1.6x10	开口销GB91-1.6x10	1	
12	255015020002	Fixed seat	固定座	1	
13	255015010005	Adjustable lever	调节杆焊合	1	
14	255015020021	Screw	调节螺钉	1	
15	911200100004	Grease nipple JB7940.1-M10x1	油杯JB7940.1-M10x1	1	
16	940500200016	Bushing Φ16xΦ18x16-SF-1	复合套(带肩)Φ16xΦ18x16-SF-1	2	
17	255011510003	Shaft %c16x135	带耳轴%c16x135	1	
18	910400100005	Washer GB97.1-6-200HV	平垫圈GB97.1-6-200HV	1	
19	910400500005	Washer GB93-6	弹簧垫圈GB93-6	1	
20	910100300009	Bolt GB5783-M6x12-8.8	螺栓GB5783-M6x12-8.8	1	
21	910100300036	Bolt GB5783-M10x25-8.8	螺栓GB5783-M10x25-8.8	4	
22	910400500007	Washer GB93-10	弹簧垫圈GB93-10	4	
23	910400100007	Washer GB97.1-10-200HV	平垫圈GB97.1-10-200HV	4	
24	255015010004	Support welding	支座焊合	1	
25	255015010002	Steering gear	转向器	1	

脚制动操纵/Foot brake

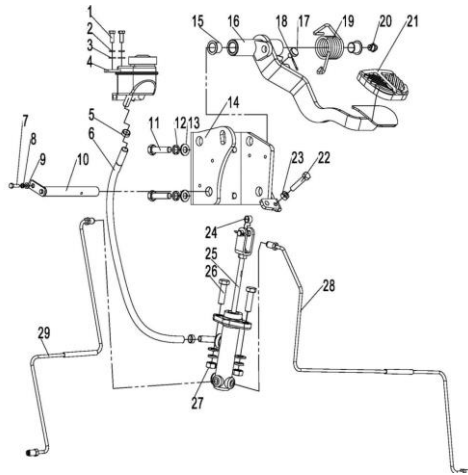

序号/NO	编码/SN	Name	名称	数量/QTY	备注/Remarks
1	910100300010	Bolt GB5783-M6x16-8.8	螺栓GB5783-M6x16-8.8	2	
2	910400500005	Washer GB93-6	弹簧垫圈GB93-6	2	
3	910400100005	Washer GB97.1-6-200HV	平垫圈GB97.1-6-200HV	2	
4	255011510006	Grease nipple	油杯	1	
5	911000600001	Hose clamp QC/T390-(11-14)	喉箍QC/T390-(11-14)	2	
6	255011520021	Connecting pipe	连接管	1	
7	910100300003	Bolt GB5783-M5x12-8.8	螺栓GB5783-M5x12-8.8	1	
8	910400500004	Washer GB93-5	弹簧垫圈GB93-5	1	
9	910400100004	Washer GB97.1-5-200HV	平垫圈GB97.1-5-200HV	1	
10	255011510003	Axle $\Phi 16 \times 135$	带耳轴 $\Phi 16 \times 135$	1	
11	910100300039	Bolt GB5783-M10x40-8.8	螺栓GB5783-M10x40-8.8	4	
12	910400500007	Washer GB93-10	弹簧垫圈GB93-10	6	
13	910400100007	Washer GB97.1-10-200HV	平垫圈GB97.1-10-200HV	6	
14	255011510004	Foot brake holder welding	脚制动支架焊接	1	
15	940500100006	Bushing $\Phi 16 \times \Phi 18 \times 15$ -SF-1	复合套 $\Phi 16 \times \Phi 18 \times 15$ -SF-1	2	
16	255011510002	Pedal welding	踏板焊接	1	
17	255011520010	Damping pad	缓冲垫	1	
18	910600600015	Split pin GB91-2x20	开口销GB91-2x20	1	
19	255011520008	Spring	扭簧	1	
20	911200100004	Grease nipple JB7940.1-M10x1	油杯JB7940.1-M10x1	1	
21	255011520013	Pedal (rubber)	踏板(橡胶)	1	
22	910100100023	Bolt GB5782-M8x45-8.8	螺栓GB5782-M8x45-8.8	1	
23	910300100006	Nut GB6170-M8-10	螺母GB6170-M8-10	1	
24	940500100048	Bushing $\Phi 10 \times \Phi 12 \times 8$ -SF-1	复合套 $\Phi 10 \times \Phi 12 \times 8$ -SF-1	1	
25	255011510001	Brake pump assembly	制动泵总成	1	
26	910100300038	Bolt GB5783-M10x35-8.8	螺栓GB5783-M10x35-8.8	2	
27	910300100007	Nut GB6170-M10-10	螺母GB6170-M10-10	2	
28	255011510009	Hydraulic steel pipe welding 2	液压钢管焊接2	1	
29	255011510010	Hydraulic steel pipe welding 1	液压钢管焊接1	1	

制动操纵/Parking brake

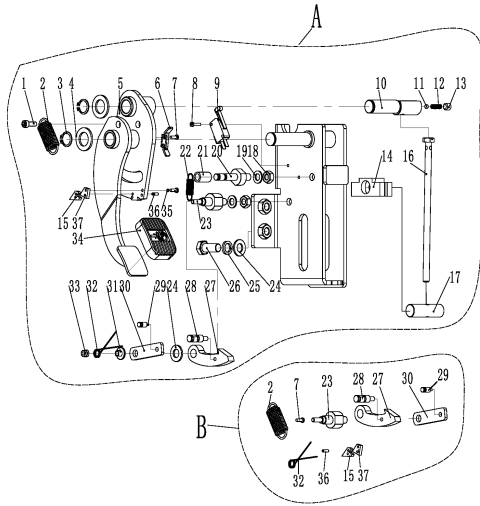

序号/NO	编码/SN	Name	名称	数量/QTY	备注/Remarks
A	255012010001	Parking brake assembly	驻车制动总成	1	
1	▲	Screw GB70.1-M5x16-8.8	螺钉GB70.1-M5x16-8.8	1	
2	▲	Spring 2	拉簧2	1	
3	▲	Circlip GB894.1-16	轴用弹性挡圈GB894.1-16	2	
4	▲	Washer GB97.1-16-200HV	平垫圈GB97.1-16-200HV	2	
5	▲	Pedal welding	踏板焊合	1	
6	▲	Baffle	挡板	1	
7	▲	Screw GB818-M3x8-4.8	螺钉GB818-M3x8-4.8	5	
8	▲	Screw GB818-M3x20-4.8	螺钉GB818-M3x20-4.8	2	
9	920200300009	Micro switch RV-166-1C25	微动开关	1	
10	▲	Shaft	挡轴	1	
11	▲	Steel ball GB308-5.5	钢球GB308-5.5	1	
12	▲	Spring	压簧	1	
13	▲	Screw GB77-M8x8-45H	螺钉GB77-M8x8-45H	1	
14	▲	Assembly seat	安装座	1	
15	▲	Board 3	板3	1	
16	▲	M8x170 Bolt	M8x170螺栓	1	
17	▲	Axle	挡轴	1	
18	▲	Nut GB6170-M8-10	螺母GB6170-M8-10	2	
19	▲	Washer GB97.1-8-200HV	平垫圈GB97.1-8-200HV	2	
20	▲	Axle 3	轴3	1	
21	▲	Polyurethane tube	聚氨酯管	1	
22	▲	Spring 1	拉簧1	1	
23	▲	Axle 4	轴4	1	
24	▲	Washer GB97.1-10-200HV	平垫圈GB97.1-10-200HV	4	
25	▲	Washer GB93-10	弹簧垫圈GB93-10	3	
26	▲	Bolt GB5783-M10x25-8.8	螺栓GB5783-M10x25-8.8	3	
27	▲	Board 2	板2	1	
28	▲	Axle 1	轴1	1	
29	▲	Axle 2	轴2	1	
30	▲	Board 1	板1	1	
31	▲	Spring seat	扭簧座	1	
32	▲	Spring	扭簧	1	
33	▲	Nut GB889.1-M5-10	螺母GB889.1-M5-10	1	
34	▲	Pedal pad	踏板垫	1	
35	▲	Washer GB93-3	弹簧垫圈GB93-3	3	
36	▲	Dowel pin GB879.1-2.5x10	弹性圆柱销GB879.1-2.5x10	1	
37	▲	Board 2	板2	1	
B	255098512001	Parking brake repair kit	驻车制动器修理包	1	

转向桥及安装(DW)/Steering axle and installation(DW)

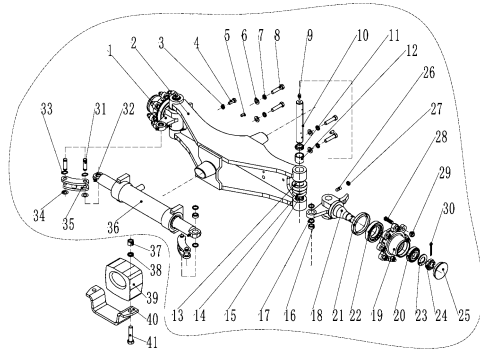

序号/NO	编码/SN	Name	名称	数量/QTY	备注/Remarks
A	255016010001	2.5T steering axle	2.5T转向桥	1	FE4P30N
A	256116010001	3.5T steering axle	3.5T转向桥	1	FE4P35N
1	255098526004	Left knuckle assembly	左转向节总成	1	
2	255098526001	Steering bridge assembly	转向桥体总成	1	FE4P30N
2	256198526001	Steering bridge assembly	转向桥体总成	1	FE4P35N
3	910300100008	Nut GB6170-M12-10	螺母GB6170-M12-10	2	
4	910100300052	Bolt GB5783-M12x40-8.8	螺栓GB5783-M12x40-8.8	2	
5	255098526008	Dowel pin10x20	销A 10x20	2	
6	255098526042	Adjusting washer	调整垫	2	
7	910400500009	Washer GB93-14	弹簧垫圈GB93-14	4	
8	255098526021	Bolt M14x40	螺栓M14x40	4	
9	255098526025	Grease nipple	弯颈式油嘴	6	
10	255098526007	Pin	转向节主销	2	
11	255098516023	Oil seal	铁壳油封	4	
12	255098526006	Bearing32X40X32	滚针轴承32X40X32	4	
13	255098526005	Bearing	单向轴承32TA6-12	2	FE4P30N
13	256198526005	Bearing	单向轴承	2	FE4P35N
14	255098526010	Pad	转向节调整垫	8	
15	255098526022	O ring	O型圈	2	
16	255098526027	ES Bearing	ES型向心关节轴承GE16ES	4	
17	255098526018	Bushing	衬套	8	
18	255098526020	Right knuckle assembly 1	右转向节总成	1	
19	255098526016	Steering wheel hub	轮毂	2	
20	255098526012	Bearing 30207	轴承30207	2	
21	255098526009	Seal ring	油封75X100X10	2	
22	255098526011	Bearing 32209	轴承32209	2	
23	910400100016	Washer GB97.1-30-200HV	平垫圈GB97.1-30-200HV	2	
24	255098526013	Nut M30x2	螺母M30x2	2	
25	255098526015	Wheel hub cover	轮毂盖	2	
26	255098526043	Screw M12X30	紧定螺钉M12X30	2	
27	910300100008	Nut GB6170-M12-10	螺母GB6170-M12-10	2	
28	255098526040	Rim Bolt	轮毂螺栓	16	
29	255098526041	Rim Nut	轮毂螺母	16	
30	255098526014	Pin	销6.3x55	2	
31	255098526026	Linking pin	连杆销	4	
32	255098526019	Grease nipple	直通式滑脂嘴	4	
33	910401300007	Circlip GB894.1-16	轴用弹性挡圈GB894.1-16	4	
34	255098526044	Adjusting washer	调整垫	2	
35	255098526002	Linking rod	连杆	2	
36	255098516003	Steering cylinder assembly	转向油缸	1	
37	910400500010	Washer GB93-16	弹簧垫圈GB93-16	4	
38	910300100010	Nut GB6170-M16-10	螺母GB6170-M16-10	4	
39	255016020001	Anti vibration pad	减震垫	2	
40	255021520091	Fixing plate	固定板	2	
41	910100300071	Bolt GB5783-M16x45-8.8	螺栓GB5783-M16x45-8.8	4	

转向桥及安装(KD)/Steering axle and installation(KD)

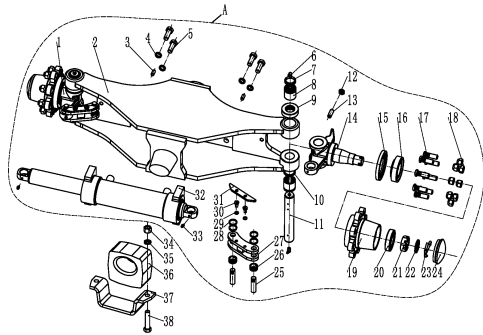

序号/NO	编码/SN	Name	名称	数量/QTY	备注/Remarks
A	255016010004	Steering axle	转向桥总成	1	包括Inc.1-33
1	255098526050	Left knuckle	左转向节	1	
2	255098526051	Steering bridge	转向桥体	1	
3	255098526052	Dowel pin10x20	圆柱销A10x20	2	
4	255098526053	Washer GB93-14	垫圈14	4	
5	255098526054	Bolt GB5783-M12x40-8.8	螺栓 M12x45	2	
6	255098526055	Grease nipple	90° 压注油杯	4	
7	255098526056	Oil seal 32X40X6/8	防尘圈32X40X6/8	4	
8	255098526057	Bearing 943/32	滚针轴承943/32	4	
9	255098526058	Bearing	推力轴承19806	2	
10	255098526059	O ring	O型圈d32x4.8	2	
11	255098526060	Pin	主销	2	
12	255098526061	Nut GB6170-M12-10	螺母M12	2	
13	255098526062	Screw M12X30	紧定螺钉M12X30	2	
14	255098526063	Right knuckle assembly	右转向节总成	1	
15	255098526064	Seal ring	油封75X100X10	2	
16	255098526065	Bearing 32209	圆锥滚子轴承32209	2	
17	255098526066	Rim Bolt	轮毂螺栓	16	
18	255098526067	Rim Nut	轮毂螺母	16	
19	255098526068	Steering wheel hub	轮毂	2	
20	255098526069	Bearing 30207	圆锥滚子轴承30207	2	
21	255098526070	Nut M30x2	槽螺母M30x2	2	
22	255098526071	Washer GB97.1-30-200HV	垫圈30	2	
23	255098526073	Pin	开口销6.3x55	2	
24	255098526074	Wheel hub cover	轮毂盖	2	
25	255098526075	Linking pin	连杆销	4	
26	255098526076	Bearing GE16ES	向心关节轴承GE16ES	4	
27	255098526077	Linking rod	连杆	2	
28	255098526078	Bushing	衬套	8	
29	255098526079	Spring washer 8	弹垫8	4	
30	255098526080	Bolt M8X18	螺栓M8X18	4	
31	255098526081	Snape-gauge	卡板	2	
32	255098526082	Grease nipple	直通式滑脂嘴	4	
33	255098526083	Steering cylinder assembly	转向油缸	1	
34	910400500010	Washer GB93-16	弹簧垫圈GB93-16	4	
35	910300100010	Nut GB6170-M16-10	螺母GB6170-M16-10	4	
36	255016020001	Anti vibration pad	减震垫	2	
37	255021520091	Fixing plate	固定板	2	
38	910100300071	Bolt GB5783-M16x45-8.8	螺栓GB5783-M16x45-8.8	4	

多路换向阀操纵(二联)/Multiple directional control valve (bigeminy)

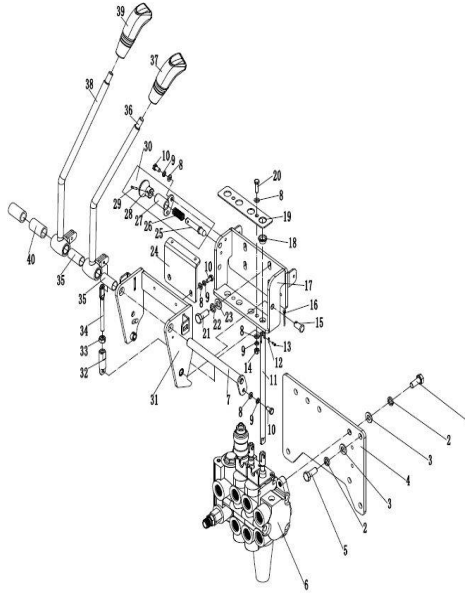

序号/NO	编码/SN	Name	名称	数量/QTY	备注/Remarks
1	910100400003	Bolt GB5786-M10x1.25x25-8.8	螺栓GB5786-M10x1.25x25-8.8	3	
2	910400500007	Washer GB93-10	弹簧垫圈GB93-10	6	
3	910400100007	Washer GB97.1-10-200HV	平垫圈GB97.1-10-200HV	6	
4	255024520024	Supporting plate	支架板	1	
5	910100300036	Bolt GB5783-M10x25-8.8	螺栓GB5783-M10x25-8.8	3	
6	255024510007	Multi way valve (two)	多路阀(二联)	1	
6	251124510002	Multi way valve (two) solenoid valve	多路阀(二联/下降电磁阀)	1	选装CE
7	255024510009	Axle φ16x168	带耳轴 φ16x168	1	
8	910400100005	Washer GB97.1-6-200HV	平垫圈GB97.1-6-200HV	9	
9	910400500005	Washer GB93-6	弹簧垫圈GB93-6	7	
10	910100300009	Bolt GB5783-M6x12-8.8	螺栓GB5783-M6x12-8.8	5	
11	255024520018	Transition rod	过渡杆	3	
12	910600600026	Split pin GB91-3.2x20	开口销GB91-3.2x20	6	
13	910600700032	Short axle GB882-10x20c1B	销轴GB882-10x20c1B	6	
14	910300100005	Nut GB6170-M6-10	螺母GB6170-M6-10	2	
15	910600600026	Split pin GB91-3.2x20	开口销GB91-3.2x20	2	
16	910600700032	Short axle GB882-10x20c1B	销轴GB882-10x20c1B	2	
17	255024510002	Fixed seat	固定座	1	
18	940500200022	Bushing φ12xφ14x20-SF-1	复合套(带肩) φ12x φ14x20-SF-1	2	
19	255024520016	Pressing plate	压板	1	
20	910100300011	Bolt GB5783-M6x20-8.8	螺栓GB5783-M6x20-8.8	2	
21	910100300023	Bolt GB5783-M8x25-8.8	螺栓GB5783-M8x25-8.8	4	
22	910400500006	Washer GB93-8	弹簧垫圈GB93-8	4	
23	910400100006	Washer GB97.1-8-200HV	平垫圈GB97.1-8-200HV	4	
24	255024520001	Fixing plate	固定板	1	
25	▲	Axle φ10x60	手柄轴 φ10x60	1	
26	▲	Spring	弹簧	1	
27	▲	Axle φ18x27.5	带耳轴 φ18x27.5	1	
28	▲	Handle	手柄	1	
29	▲	Dowel pin GB879.1-3x16	弹性圆柱销GB879.1-3x16	1	
30	255024510006	Handle assembly	解锁手柄总成	1	包含/Inc. 25-29
31	255024510001	Holder welding	支架焊合	1	
32	255025020008	Joint	接头	2	
33	910300100006	Nut GB6170-M8-10	螺母GB6170-M8-10	2	
34	255024520017	Connecting rod	连接杆	2	
35	940500100006	Bearing bushing φ18xφ16x37	无油轴承套φ18xφ16x37	2	
36	255024510004	Control lever welding (lifting)	操纵杆焊合(起升)	1	
37	255024520022	Handle ball (lifting)	手柄球(起升)	1	
38	255024510005	Control lever welding (slope)	操纵杆焊合(倾斜)	1	
39	255024520023	Handle ball (slope)	手柄球(倾斜)	1	
40	255024520028	Sleeve	轴套	2	

多路换向阀操纵纵(三联)/Multiple directional control valve (trigeminy)

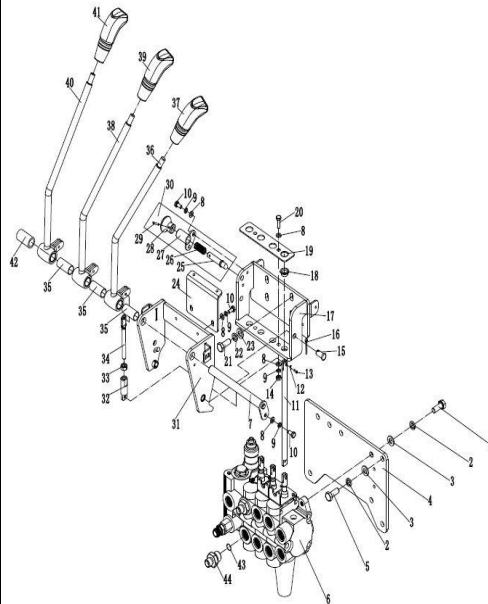

序号/NO	编码/SN	Name	名称	数量/QTY	备注/Remarks
1	910100400003	Bolt GB5786-M10x1.25x25-8.8	螺栓GB5786-M10x1.25x25-8.8	3	
2	910400500007	Washer GB93-10	弹簧垫圈GB93-10	6	
3	910400100007	Washer GB97.1-10-200HV	平垫圈GB97.1-10-200HV	6	
4	255024520024	Supporting plate	支架板	1	
5	910100300036	Bolt GB5783-M10x25-8.8	螺栓GB5783-M10x25-8.8	3	
6	255025010002	Multi way valve (four combined)	多路阀(三联)	1	
6	251125010002	Multi way valve (three) solenoid valve	多路阀(三联/下降电磁阀)	1	选装CE
7	255024510009	Axle φ16x168	带耳轴 φ16x168	1	
8	910400100005	Washer GB97.1-6-200HV	平垫圈GB97.1-6-200HV	9	
9	910400500005	Washer GB93-6	弹簧垫圈GB93-6	7	
10	910100300009	Bolt GB5783-M6x12-8.8	螺栓GB5783-M6x12-8.8	5	
11	255024520018	Transition rod	过渡杆	3	
12	910600600026	Split pin GB91-3.2x20	开口销GB91-3.2x20	9	
13	910600700032	Short axle GB882-10x20c1B	销轴GB882-10x20c1B	9	
14	910300100005	Nut GB6170-M6-10	螺母GB6170-M6-10	2	
15	910600600026	Split pin GB91-3.2x20	开口销GB91-3.2x20	2	
16	910600700032	Short axle GB882-10x20c1B	销轴GB882-10x20c1B	2	
17	255024510002	Fixing seat	固定座	1	
18	940500200022	Bushing φ12xφ14x20-SF-1	复合套(带肩) φ12x φ14x20-SF-1	3	
19	255024520016	Pressing plate	压板	1	
20	910100300011	Bolt GB5783-M6x20-8.8	螺栓GB5783-M6x20-8.8	2	
21	910100300023	Bolt GB5783-M8x25-8.8	螺栓GB5783-M8x25-8.8	4	
22	910400500006	Washer GB93-8	弹簧垫圈GB93-8	4	
23	910400100006	Washer GB97.1-8-200HV	平垫圈GB97.1-8-200HV	4	
24	255024520001	Fixing plate	固定板	1	
25	▲	Axle φ10x60	手柄轴 φ10x60	1	
26	▲	Spring	弹簧	1	
27	▲	Axle φ18x27.5	带耳轴 φ18x27.5	1	
28	▲	Handle	手柄	1	
29	▲	Dowel pin GB879.1-3x16	弹性圆柱销GB879.1-3x16	1	
30	255024510006	Handle assembly	解锁手柄总成	1	包含/Inc. 25-29
31	255024510001	Holder welding	支架焊接	1	
32	255025020008	Joint	接头	3	
33	910300100006	Nut GB6170-M8-10	螺母GB6170-M8-10	3	
34	255024520017	Linking rod	连接杆	3	
35	940500100006	Bearing φ18xφ16x15	无油轴承套φ18xφ16x15	3	
36	255024510004	Control lever welding (lifting)	操纵杆焊接(起升)	1	
37	255024520022	Handle ball (lifting)	手柄球(起升)	1	
38	255024510005	Control lever welding (slope)	操纵杆焊接(倾斜)	1	
39	255024520023	Handle ball(slope)	手柄球(倾斜)	1	
40	255025010001	Control lever welding (accessory 1)	操纵杆焊接(属具1)	1	
41	255025020002	Handle ball (accessory 1)	手柄球(属具1)	1	
42	255024520028	Sleeve	袖套	1	
43	910800100003	O ring 17x2.65	O形圈-内17x2.65	2	
44	255023520033	Jointφ8-M20x1.5-M16x1.5-60°	接头(直)8-M20x1.5-M16x1.5-60°	2	

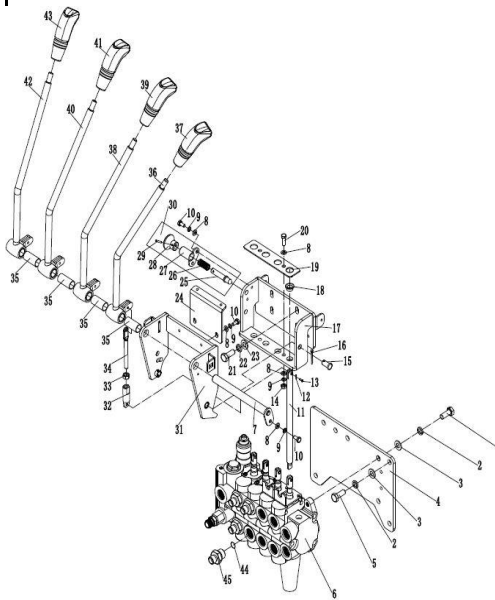

多路换向阀操纵纵(四联)/Multiple directional control valve(four joint)

序号/NO	编码/SN	Name	名称	数量/QTY	备注/Remarks
1	910100400003	Bolt GB5786-M10x1.25x25-8.8	螺栓GB5786-M10x1.25x25-8.8	3	
2	910400500007	Washer GB93-10	弹簧垫圈GB93-10	6	
3	910400100007	Washer GB97.1-10-200HV	平垫圈GB97.1-10-200HV	6	
4	255024520024	Supporting plate	支架板	1	
5	910100300036	Bolt GB5783-M10x25-8.8	螺栓GB5783-M10x25-8.8	3	
6	255025510002	Multi way valve (four combined)	多路阀(四联)	1	
6	251125510002	Multi way valve (four) solenoid valve	多路阀(四联/下降电磁阀)	1	选装CE
7	255024510009	Axle φ16x168	带耳轴 φ16x168	1	
8	910400100005	Washer GB97.1-6-200HV	平垫圈GB97.1-6-200HV	9	
9	910400500005	Washer GB93-6	弹簧垫圈GB93-6	7	
10	910100300009	Bolt GB5783-M6x12-8.8	螺栓GB5783-M6x12-8.8	5	
11	255024520018	Transition rod	过渡杆	4	
12	910600600026	split pin GB91-3.2x20	开口销GB91-3.2x20	12	
13	910600700032	Short axle GB882-10x20c1B	销轴GB882-10x20c1B	12	
14	910300100005	Nut GB6170-M6-10	螺母GB6170-M6-10	2	
15	910600600026	split pin GB91-3.2x20	开口销GB91-3.2x20	2	
16	910600700032	Short axle GB882-10x20c1B	销轴GB882-10x20c1B	2	
17	255024510002	Fixing seat	固定座	1	
18	940500200022	Bushing φ12xφ14x20-SF-1	复合套(带肩) φ12x φ14x20-SF-1	4	
19	255024520016	Pressing plate	压板	1	
20	910100300011	Bolt GB5783-M6x20-8.8	螺栓GB5783-M6x20-8.8	2	
21	910100300023	Bolt GB5783-M8x25-8.8	螺栓GB5783-M8x25-8.8	4	
22	910400500006	Washer GB93-8	弹簧垫圈GB93-8	4	
23	910400100006	Washer GB97.1-8-200HV	平垫圈GB97.1-8-200HV	4	
24	255024520001	Fixing plate	固定板	1	
25	▲	Axle φ10x60	手柄轴 φ10x60	1	
26	▲	Spring	弹簧	1	
27	▲	Axle φ18x27.5	带耳轴 φ18x27.5	1	
28	▲	Handle	手柄	1	
29	▲	Dowel pin GB879.1-3x16	弹性圆柱销GB879.1-3x16	1	
30	255024510006	Handle assembly	解锁手柄总成	1	包含/Inc. 25-29
31	255024510001	Holder welding	支架焊合	1	
32	255025020008	Joint	接头	4	
33	910300100006	Nut GB6170-M8-10	螺母GB6170-M8-10	4	
34	255024520017	Connecting rod	连接杆	4	
35	940500100006	Bearing bushing φ18xφ16x37	无油轴承套 φ18 φ16x37	4	
36	255024510004	Control lever welding(lifting)	操纵杆焊合(起升)	1	
37	255024520022	Handle ball(lifting)	手柄球(起升)	1	
38	255024510005	Control lever welding(slope)	操纵杆焊合(倾斜)	1	
39	255024520023	Handle ball (slope)	手柄球(倾斜)	1	
40	255025010001	Control lever welding(accessory 1)	操纵杆焊合(属具1)	1	
41	255025020002	Handle ball(accessory 1)	手柄球(属具1)	1	
42	255025510001	Control lever welding (accessory 2)	操纵杆焊合(属具2)	1	
43	255025520002	Handle ball (accessory 2)	手柄球(属具2)	1	
44	910800100003	Oring 17x2.65	O形圈-内17x2.65	4	
45	255023520033	Joint 8-M20x1.5-M16x1.5-60°	接头(直)8-M20x1.5-M16x1.5-60°	4	

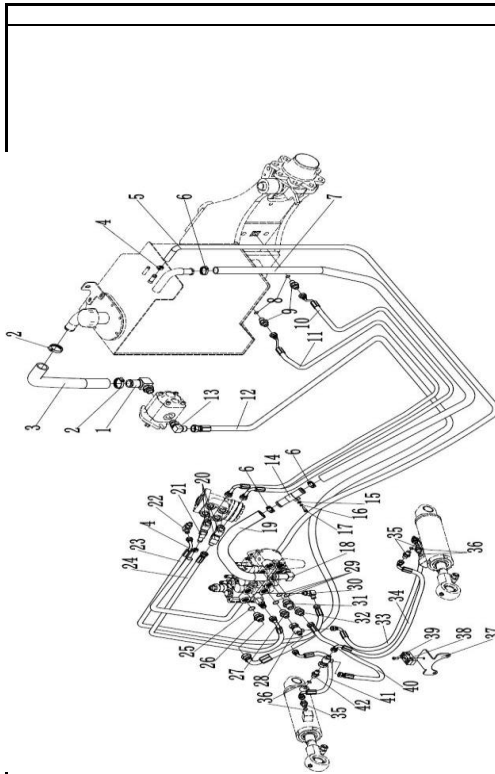

液压系统/Hydraulic system

序号/NO	编码/SN	Name	名称	数量/QTY	备注/Remarks
1	255023510005	Joint 25-G1-φ32	接头(转向弯)25-G1-φ32	1	
2	911000600006	Hose clamp QC/T390-(40-45)	喉箍QC/T390-(40-45)	2	
3	255023520008	Rubber hose	胶管(吸油)	1	
4	911000600003	Hose clamp QC/T390-(22-26)	喉箍QC/T390-(22-26)	2	
5	255023520006	Oil return hose φ23xφ13x3600	回油管 φ23xφ13x3600	1	
6	911000600004	Hose clamp QC/T390-(34-38)	喉箍QC/T390-(34-38)	4	
7	900200401003	Oil return hose φ35xφ25x2050	回油管 φ35xφ25x2050	1	
8	910800100002	O-ring 13.2x2.65	O形圈-内13.2x2.65	2	
9	255023520034	Joint 8-2xM16x1.5-60°	接头(直)8-2xM16x1.5-60°	2	
10	256023520002	Hydraulic hose assembly 8-L2850-1SC-60°	液压管总成(异)8-L2850-1SC-60°	1	
11	256023520001	Hydraulic hose assembly 8-L3150-1SC-60°	液压管总成(异)8-L3150-1SC-60°	1	
12	256023520004	Hydraulic hose assembly (90°)13-L2900-2SC-60°	液压管总成(90°)13-L2900-2SC-60°	1	
13	255023520035	Joint12-G1/2-M22x1.5-60°	接头(锁定弯)12-G1/2-M22x1.5-60°	1	
14	255023520022	Transition steel pipe	过渡钢管	1	
15	910400100005	Washer GB97.1-6-200HV	平垫圈GB97.1-6-200HV	2	
16	910400500005	Washer GB93-6	弹垫圈GB93-6	2	
17	910200200036	Screw GB70.1-M6x20-8.8	螺钉GB70.1-M6x20-8.8	2	
18	255023510002	Joint 16-M22x1.5-φ25	接头(转向弯)16-M22x1.5-φ25	1	
19	255023520021	Rubber tube	胶管(回油)	1	
20	255023510007	Joint 8-M18x1.5-M16x1.5-60°	接头(锁定弯)10-M20x1.5-M16x1.5-60°	3	
21	255023520033	Joint 11-M18x1.5-0	接头(锁定弯)11-M20x1.5-0	1	
22	255023510003	Joint 6-G1/4-M14x1.5-60°	接头(锁定弯)6-G1/4-M14x1.5-60°	1	
23	255023520003	Hydraulic hose assembly (90°)6-L1420-1SC-60°	液压管总成(90°)6-L1420-1SC-60°	1	
24	255023520005	Hydraulic hose assembly (90°)8-L1420-1SC-60°	液压管总成(90°)8-L1420-1SC-60°	1	
25	910800100015	O-ring 19x2.65	O形圈-内19x2.65	1	
26	255023520030	Joint 12-2xM22x1.5-60°	接头(直)12-2xM22x1.5-60°	1	
27	255023520033	Joint 8-M20x1.5-M16x1.5-60°	接头(直)8-M20x1.5-M16x1.5-60°	1	
28	250523510001	Joint 7-2xM14x1.5-M16x1.5-60°	接头(三通)7-2xM14x1.5-M16x1.5-60°	2	
29	910800100003	O-ring 17x2.65	O形圈-内17x2.65	3	
30	255023510001	Joint 6-M12x1.5-M14x1.5-60°	接头(锁定弯)6-M12x1.5-M14x1.5-60°	1	
31	255044020122	Joint 12-M20x1.5-M22x1.5-60°	接头(直)12-M20x1.5-M22x1.5-60°	1	
32	255023520032	Joint 6-M20x1.5-M14x1.5-60°	接头(直)6-M20x1.5-M14x1.5-60°	1	
33	255023520017	Hydraulic hose assembly 6-L1000-1SC-60°	液压管总成U型6-L1000-1SC-60°	1	
34	255023520018	Hydraulic hose assembly 6-L1100-1SC-60°	液压管总成(异)6-L1100-1SC-60°	1	
35	255023520007	Joint 6-G1/4-M14x1.5-60°	接头(直)6-G1/4-M14x1.5-60°	3	
36	910800100021	O-ring 11.2x2.65	O形圈-内11.2x2.65	4	
37	255023520027	Rubber hose fixing block	胶管固定板	1	
38	255028520034	Rubber hose fixing block	胶管固定块	2	
39	910200200060	Screw GB70.1-M8x35-8.8	螺钉GB70.1-M8x35-8.8	1	
40	255023520012	Hydraulic hose assembly 6-L500-1SC-60°	液压管总成(直)6-L500-1SC-60°	1	
41	255023520016	Hydraulic hose assembly 6-L600-1SC-60°	液压管总成U型6-L600-1SC-60°	1	
42	255023520019	Joint 8-G1/4-M16x1.5-60°	接头(直)8-G1/4-M16x1.5-60°	1	

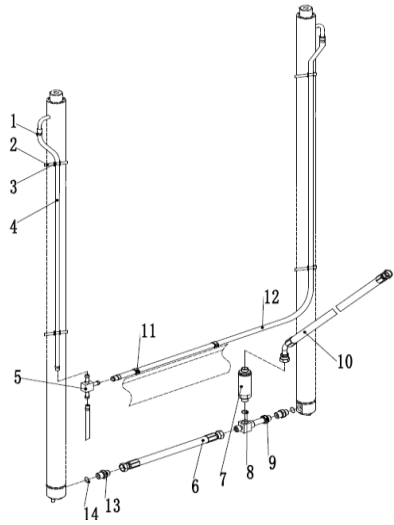

门架起升管路(标准门架) / Mast lifting pipeline (standard mast)

序号/NO	编码/SN	Name	名称	数量/QTY	备注/Remarks
1	255044020043	Hoop	卡箍	6	
2	921600400002	Strip 8x300	扎带8x300	4	
3	255044020042	Press plate	压板	4	
4	▲	Oil return hose1L=620	回油管1L=620	2	H=2000
	▲	Oil return hose1L=870	回油管1L=870	2	H=2500
	▲	Oil return hose1L=1120	回油管1L=1120	2	H=3000
	▲	Oil return hose1L=1270	回油管1L=1270	2	H=3300
	▲	Oil return hose1L=1370	回油管1L=1370	2	H=3500
	▲	Oil return hose1L=1420	回油管1L=1420	2	H=3600
	▲	Oil return hose1L=1470	回油管1L=1470	2	H=3700
	▲	Oil return hose1L=1620	回油管1L=1620	2	H=4000
	▲	Oil return hose1L=1770	回油管1L=1770	2	H=4300
	▲	Oil return hose1L=1920	回油管1L=1920	2	H=4500
	▲	Oil return hose1L=2120	回油管1L=2120	2	H=5000
	▲	Oil return hose1L=2370	回油管1L=2370	2	H=5500
▲	Oil return hose1L=2620	回油管1L=2620	2	H=6000	
5	255044020118	Joint	接头(三通)	1	
6	255044020150	Hydraulic hose assembly 15-L360-2SC-60°	液压管总成(直)15-L360-2SC-60°	1	
7	950700300003	Speed limit valve XSF-F16L-60	限速阀XSF-F16L-60	1	
8	910800100040	O-ring-out 24x2.4	O形圈-外24x2.4	1	
9	255044010040	Joint	接头(三通)	1	
10	255044020013	Hydraulic hose assembly (135°)15-L740-2SC-60°	液压管总成(135°)15-L740-2SC-60°	1	
11	921600400003	Strip P-N156-00646	扎带(带扣)P-N156-00646	2	
12	▲	Oil return hose2	回油管2	1	
13	910800100003	O-ring 17x2.65	O形圈-内17x2.65	3	
14	255044020122	Joint 12-M20x1.5-M22x1.5-60°	接头(直)12-M20x1.5-M22x1.5-60°	1	

门架起升管路 (三级全自由)/Mast lifting pipeline(three stage full free lift)

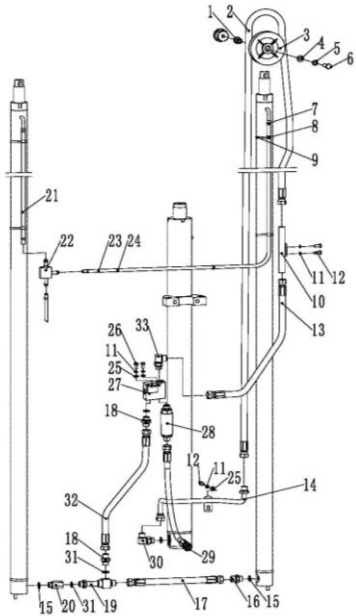

序号/NO	编码/SN	Name	名称	数量/QTY	备注/Remarks
1	255044520081	Bushing	衬套	1	
2	255044520084	Hydraulic hose assembly 15-L1910-2SC-60°	液压管总成(直)15-L1910-2SC-60°	1	H=3600
	255044520071	Hydraulic hose assembly 15-L2180-2SC-60°	液压管总成(直)15-L2180-2SC-60°	1	H=4000
	255044520072	Hydraulic hose assembly 15-L2430-2SC-60°	液压管总成(直)15-L2430-2SC-60°	1	H=4350
	255044520073	Hydraulic hose assembly 15-L2530-2SC-60°	液压管总成(直)15-L2530-2SC-60°	1	H=4500
	255044520074	Hydraulic hose assembly 15-L2730-2SC-60°	液压管总成(直)15-L2730-2SC-60°	1	H=4700/4800
	255044520075	Hydraulic hose assembly 15-L3015-2SC-60°	液压管总成(直)15-L3015-2SC-60°	1	H=5000
	255044520076	Hydraulic hose assembly 15-L3480-2SC-60°	液压管总成(直)15-L3480-2SC-60°	1	H=5400/5500
	255044520077	Hydraulic hose assembly 15-L3950-2SC-60°	液压管总成(直)15-L3950-2SC-60°	1	H=6000
	255044520124	Hydraulic hose assembly 15-L4410-2SC-60°	液压管总成(直)15-L4410-2SC-60°	1	H=6500
	253044520063	Hydraulic hose assembly 15-L4410-2SC-60°	液压管总成(直)15-L4410-2SC-60°	1	H=7000
3	255044520096	Pulley	滑轮Φ120x36(单槽)	1	
4	910400100008	Washer GB97.1-12-200HV	平垫圈GB97.1-12-200HV	1	
5	910400500008	Washer GB93-12	弹簧垫圈GB93-12	1	
6	910100300054	Bolt GB5783-M12x50-8.8	螺栓GB5783-M12x50-8.8	1	
7	255044020043	Hoop 13	卡箍13	5	
8	921600400002	Strip 8x300	扎带8x300	6	
9	255044020042	Press plate	压板	6	
10	255044510020	Hydraulic steel pipe welding	液压钢管焊合	1	
11	910400500006	Washer GB93-8	弹簧垫圈GB93-8	5	
12	910100300022	Bolt GB5783-M8x20-8.8	螺栓GB5783-M8x20-8.8	3	
13	255044520083	Hydraulic hose assembly 15-L530-2SC-60°	液压管总成(直)15-L530-2SC-60°	1	
14	255044510021	Hydraulic steel pipe welding	液压钢管焊合	1	
15	910800100003	O-ring 17x2.65	O形圈-内17x2.65	2	
16	255044020122	Joint 12-M20x1.5-M22x1.5-60°	接头(直)12-M20x1.5-M22x1.5-60°	1	
17	256844520011	Hydraulic hose assembly 15-L320-2SC-60°	液压管总成(直)15-L320-2SC-60°	1	
18	255023520030	Joint 12-2xM22x1.5-60°	接头(直)12-2xM22x1.5-60°	2	
19	255044010040	Joint	三通接头	1	
20	255044520080	Joint	内外接头	1	
21	▲	Oil return hose L=655	回油管L=655	1	
	▲	Oil return hose L=780	回油管L=780	1	
	▲	Oil return hose L=830	回油管L=830	1	

侧移器及管路安装 (标准门架) / Side shifter and pipeline installation (standard mast)

序号/NO	编码/SN	Name	名称	数量/QTY	备注/Remarks
1	910100100056	Bolt GB5782-M12x90-8.8	螺栓GB5782-M12x90-8.8	1	
2	910400500008	Washer GB93-12	弹簧垫圈GB93-12	1	
3	910400100008	Washer GB97.1-12-200HV	平垫圈GB97.1-12-200HV	1	
4	255030520022	Bush Φ22xΦ13x56	衬套Φ22xΦ13x56	1	
5	255030520021	Pulley Φ110x27	滑轮Φ110x27(单槽)	2	
6	910200200059	Screw GB70.1-M8x30-8.8	螺钉GB70.1-M8x30-8.8	2	
7	910400500006	Washer GB93-8	弹簧垫圈GB93-8	6	
8	255028520034	Rubber pipe lump	胶管固定块	2	
9	255028520035	Pipe press fixedly plank	管夹安装板	2	
10	255028520046	Hydraulic hose assembly (90°)10-L2950-1SC-60°	液压管总成(90°)10-L2950-1SC-60°	2	H=2000
	255028520047	Hydraulic hose assembly (90°)10-L3450-1SC-60°	液压管总成(90°)10-L3450-1SC-60°	2	H=2500
	255027520011	Hydraulic hose assembly (90°)10-L4050-1SC-60°	液压管总成(90°)10-L4050-1SC-60°	2	H=3000
	255027520012	Hydraulic hose assembly (90°)10-L4250-1SC-60°	液压管总成(90°)10-L4250-1SC-60°	2	H=3300
	255027520013	Hydraulic hose assembly (90°)10-L4400-1SC-60°	液压管总成(90°)10-L4400-1SC-60°	2	H=3500
	255027520001	Hydraulic hose assembly (90°)10-L4500-1SC-60°	液压管总成(90°)10-L4500-1SC-60°	2	H=3600
	255027520014	Hydraulic hose assembly (90°)10-L4650-1SC-60°	液压管总成(90°)10-L4650-1SC-60°	2	H=3700
	255027520015	Hydraulic hose assembly (90°)10-L5050-1SC-60°	液压管总成(90°)10-L5050-1SC-60°	2	H=4000
	255027520016	Hydraulic hose assembly (90°)10-L5350-1SC-60°	液压管总成(90°)10-L5350-1SC-60°	2	H=4300
	255027520017	Hydraulic hose assembly (90°)10-L5550-1SC-60°	液压管总成(90°)10-L5550-1SC-60°	2	H=4500
	255027520018	Hydraulic hose assembly (90°)10-L6150-1SC-60°	液压管总成(90°)10-L6150-1SC-60°	2	H=5000
	255027520019	Hydraulic hose assembly (90°)10-L6650-1SC-60°	液压管总成(90°)10-L6650-1SC-60°	2	H=5500
255027520020	Hydraulic hose assembly (90°)10-L7150-1SC-60°	液压管总成(90°)10-L7150-1SC-60°	2	H=6000	
11	255029020024	Joint 8-2XM16x1.5-60°	接头(锁定弯)8-2xM16x1.5-60°	2	
12	254127520001	fixedly plank	安装板	1	
13	910400100006	Washer GB97.1-8-200HV	平垫圈GB97.1-8-200HV	2	
14	910800100001	Oring 9.5x1.8	O形圈-内9.5x1.8	4	
15	255042520101	Hydraulic hose assembly (90°)10-L500-1SC-60°-0°	液压管总成(90°)10-L500-1SC-60°-0°	2	
16	255042510004	Side shifter assembly(LH)	侧移器总成(LH)	1	选装/optional
16	255042510001	Side shifter assembly(LD)	侧移器总成(LD)	1	选装/optional
16	255042510002	Side shifter assembly(CASCADE)	侧移器总成(卡斯卡特)	1	选装/optional

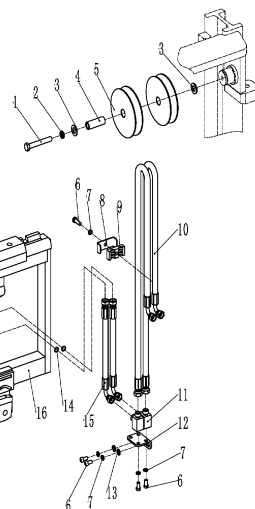

侧移器及管路安装 (二级全自由) / Side shifter and pipeline installation (two stage full free)

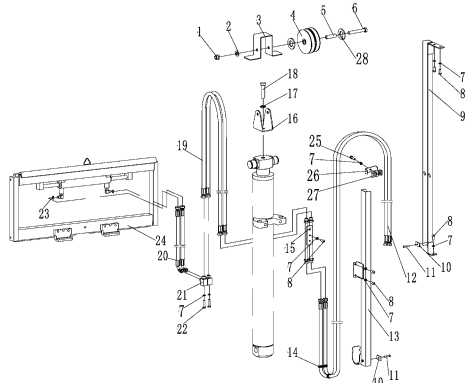

序号/NO	编码/SN	Name	名称	数量/QTY	备注/Remarks
1	910300500006	Nut GB889.1-M12-10	螺母GB889.1-M12-10	1	
2	910400100008	Washer GB97.1-12-200HV	平垫圈GB97.1-12-200HV	1	
3	255028520043	Plate	挡链板	1	
4	255030520021	Pulley $\phi 110 \times 27$	滑轮 $\phi 110 \times 27$ (单槽)	2	
5	255030520022	Bushing $\Phi 22 \times \Phi 13 \times 56$	衬套 $\Phi 22 \times \Phi 13 \times 56$	1	
6	910100100058	Bolt GB5782-M12x100-8.8	螺栓GB5782-M12x100-8.8	1	
7	910400500006	Washer GB93-8	弹簧垫圈GB93-8	11	
8	910200200057	Screw GB70.1-M8x20-8.8	螺钉GB70.1-M8x20-8.8	7	
9	255028510001	Groove welding L=670	外导槽焊合L=670	1	H=2000
	255028510002	Groove welding L=840	外导槽焊合L=840	1	H=2500
	255028510003	Groove welding L=1090	外导槽焊合L=1090	1	H=3000
	255028510004	Groove welding L=1240	外导槽焊合L=1240	1	H=3300/3500
	255028510005	Groove welding L=1390	外导槽焊合L=1390	1	H=3600/3700
	255028510006	Groove welding L=1640	外导槽焊合L=1640	1	H=4000
10	255028520052	Press plate	压板	2	
11	910200200039	Screw GB70.1-M6x30-8.8	螺钉GB70.1-M6x30-8.8	2	
12	252030520016	Hydraulic hose assembly 10-L2220-1SC-60°	液压管总成(直)10-L2220-1SC-60°	2	H=2000
	254130520009	Hydraulic hose assembly 10-L2470-1SC-60°	液压管总成(直)10-L2470-1SC-60°	2	H=2500
	263028520010	Hydraulic hose assembly 10-L2940-1SC-60°	液压管总成(直)10-L2940-1SC-60°	2	H=3000
	255030520013	Hydraulic hose assembly 10-L3180-1SC-60°	液压管总成(直)10-L3180-1SC-60°	2	H=3300/3500
	254128520039	Hydraulic hose assembly 10-L3250-1SC-60°	液压管总成(直)10-L3250-1SC-60°	2	H=3600/3700
	255028520059	Hydraulic hose assembly 10-L3600-1SC-60°	液压管总成(直)10-L3600-1SC-60°	2	H=4000
13	255028510011	Groove welding L=545	内导槽焊合L=545	1	H=2000
	255028510012	Groove welding L=670	内导槽焊合L=670	1	H=2500
	255028510013	Groove welding L=795	内导槽焊合L=795	1	H=3000
	255028510014	Groove welding L=870	内导槽焊合L=870	1	H=3300/3500
	255028510015	Groove welding L=920	内导槽焊合L=920	1	H=3600/3700
	255028510016	Groove welding L=960	内导槽焊合L=960	1	H=4000
14	921600400002	Strip 8x300	扎带8x300	2	
15	255028510022	Transition steel pipe	过渡钢管	1	
16	255030520026	Pulley frame	滑轮架体	1	
17	910100100072	Bolt GB5782-M16x60-8.8	螺栓GB5782-M16x60-8.8	1	

侧移器及管路安装(三级全自由)/Side shifter and pipeline installation(three stage full free)

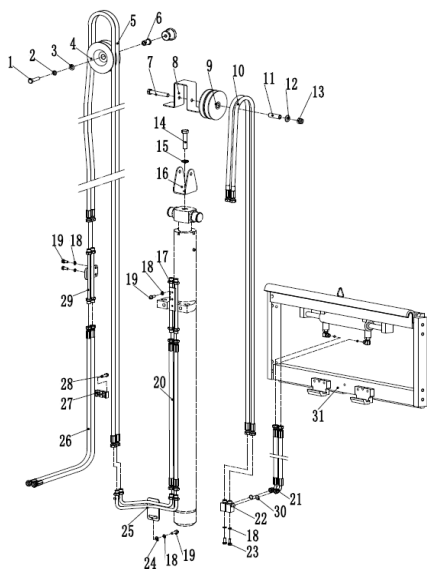

序号/NO	编码/SN	Name	名称	数量/QTY	备注/Remarks
1	910100100048	Bolt GB5782-M12x50-8.8	螺栓GB5782-M12x50-8.8	1	
2	910400500008	Washer GB93-12	弹垫圈GB93-12	1	
3	910400100008	Washer GB97.1-12-200HV	平垫圈GB97.1-12-200HV	2	
4	255030520020	Pulley Φ x36 120 (dual slot)	滑轮Φ 120x36(双槽)	1	
5	255023520036	Hydraulic hose assembly 10-L1800-1CS-60°	液压管总成(直)10-L1800-1SC-60°	1	H=3600
5	255030520001	Hydraulic hose assembly 10-L2060-1CS-60°	液压管总成(直)10-L2060-1SC-60°	1	H=4000
5	255030520002	Hydraulic hose assembly 10-L2310-1CS-60°	液压管总成(直)10-L2310-1SC-60°	1	H=4350
5	255030520003	Hydraulic hose assembly 10-L2410-1CS-60°	液压管总成(直)10-L2410-1SC-60°	1	H=4500
5	255030520004	Hydraulic hose assembly 10-L2610-1CS-60°	液压管总成(直)10-L2610-1SC-60°	1	H=4800/4700
5	255030520005	Hydraulic hose assembly 10-L2900-1CS-60°	液压管总成(直)10-L2900-1SC-60°	1	H=5000
5	255030520006	Hydraulic hose assembly 10-L3370-1CS-60°	液压管总成(直)10-L3370-1SC-60°	1	H=5500/5400
5	255030520007	Hydraulic hose assembly 10-L3840-1CS-60°	液压管总成(直)10-L3840-1SC-60°	1	H=6000
5	263030520008	Hydraulic hose assembly 10-L4330-1CS-60°	液压管总成(直)10-L4330-1SC-60°	1	H=6500
5	275228011001	Hydraulic hose assembly 10-L4650-1CS-60°	液压管总成(直)10-L4650-1SC-60°	1	H=7000
6	255030520023	Bushing	衬套1	1	
7	910100100058	Bolt GB5782-M12x100-8.8	螺栓GB5782-M12x100-8.8	1	
8	255028520043	Chain plate	挡板	1	
9	255030520021	Pulley φ110x27	滑轮φ 110x27(单槽)	2	
10	255029020011	Hydraulic hose assembly 10-L1260-1CS-60°	液压管总成(直)10-L1260-1SC-60°	2	H=3600
10	255029020014	Hydraulic hose assembly 10-L1340-1CS-60°	液压管总成(直)10-L1340-1SC-60°		H=4000
10	255029020012	Hydraulic hose assembly 10-L1410-1CS-60°	液压管总成(直)10-L1400-1SC-60°	2	H=4300
10	255030520037	Hydraulic hose assembly 10-L1500-1CS-60°	液压管总成(直)10-L1500-1SC-60°	2	H=4500
10	255028520011	Hydraulic hose assembly 10-L1620-1CS-60°	液压管总成(直)10-L1620-1SC-60°	2	H=4800/4700
10	255030520024	Hydraulic hose assembly 10-L1720-1CS-60°	液压管总成(直)10-L1720-1SC-60°	2	H=5000
10	255028520048	Hydraulic hose assembly 10-L1950-1CS-60°	液压管总成(直)10-L1950-1SC-60°	2	H=5500/5400
10	254130540001	Hydraulic hose assembly 10-L2190-1CS-60°	液压管总成(直)10-L2190-1SC-60°	2	H=6000
10	256531020701	Hydraulic hose assembly 10-L2430-1CS-60°	液压管总成(直)10-L2430-1SC-60°	2	H=6500
10	255030520004	Hydraulic hose assembly 10-L2610-1CS-60°	液压管总成(直)10-L2610-1SC-60°	2	H=7000
11	255030520022	Bush Φ 22xΦ 13x56	衬套Φ 22xΦ 13x56	1	
12	910400100008	Washer GB97.1-12-200HV	平垫圈GB97.1-12-200HV	2	
13	910300500006	Nut GB889.1-M12-10	螺母GB889.1-M12-10	1	
14	910100100072	Bolt GB5782-M16x60-8.8	螺栓GB5782-M16x60-8.8	1	

双附加管路(三级全自由)

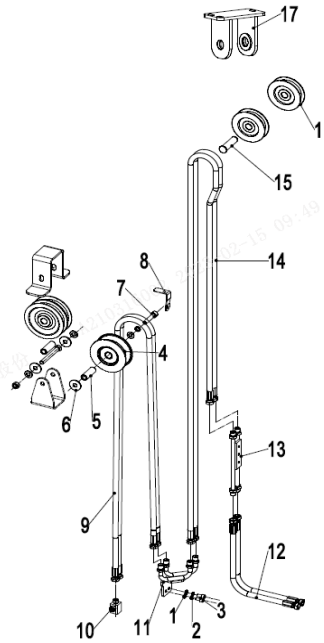

序号/NO	编码/SN	Name	名称	数量/QTY	备注/Remarks
1	910400100006	Washer GB97.1-8-200HV	平垫圈GB97.1-8-200HV	5	
2	910400500006	WasherGB93-8	弹簧垫圈GB93-8	8	
3	910100300022	Bolt GB5783-M8x20-8.8	螺栓GB5783-M8x20-8.8	7	
4	255030520021	Pulley Φ110x27	滑轮Φ110x27(单槽)	4	
5	255030520022	BushΦ20xΦ13x56	衬套Φ20xΦ13x56	1	
6	910400200005	Washer GB96.1-12-200HV	大垫圈GB96.1-12-200HV	2	
7	910100100056	Boit GB5782-M12x90-8.8	螺栓GB5782-M12x90-8.8	1	
8	255031020015	Hose baffle	胶管挡板	1	
9	255029020015	Hydraulic hose assembly 10-L1560-1SC-60°	液压管总成(直)10-L1560-1SC-60°	2	H=3600
9	255028520049	Hydraulic hose assembly 10-L1680-1SC-60°	液压管总成(直)10-L1680-1SC-60°	2	H=4000
9	255030520027	Hydraulic hose assembly 10-L1850-1SC-60°	液压管总成(直)10-L1850-1SC-60°	2	H=4350/4500
9	255028520048	Hydraulic hose assembly 10-L1950-1SC-60°	液压管总成(直)10-L1950-1SC-60°	2	H=4800/4700
9	255030520001	Hydraulic hose assembly 10-L2060-1SC-60°	液压管总成(直)10-L2060-1SC-60°	2	H=5000
9	255028520045	Hydraulic hose assembly 10-L2300-1SC-60°	液压管总成(直)10-L2300-1SC-60°	2	H=5500/5400
9	255031020100	Hydraulic hose assembly 10-L2530-1SC-60°	液压管总成(直)10-L2530-1SC-60°	2	H=6000
9	255028520050	Hydraulic hose assembly 10-L2730-1SC-60°	液压管总成(直)10-L2730-1SC-60°	2	H=6500
10	255029020024	Joint 8-2XM16x1.5-60°	接头(锁定弯)8-2xM16x1.5-60°	4	
11	255031020006	Hydraulic steel pipe welding	液压钢管焊接	1	
12	255031020008	Hydraulic hose assembly (135°)10-L1000-1SC-60°	液压管总成(135°)10-L1000-1SC-60°	2	
13	255028510022	Excessive pipe welding	过渡钢管	1	
14	263030520011	Hydraulic hose assembly 10-L2060-1SC-60°	液压管总成(直)10-L2060-1SC-60°	2	
14	255031020009	Hydraulic hose assembly 10-L2340-1SC-60°	液压管总成(直)10-L2340-1SC-60°	2	
14	255031020010	Hydraulic hose assembly 10-L2590-1SC-60°	液压管总成(直)10-L2590-1SC-60°	2	
14	263028520009	Hydraulic hose assembly 10-L2690-1SC-60°	液压管总成(直)10-L2690-1SC-60°	2	
14	255031020012	Hydraulic hose assembly 10-L2890-1SC-60°	液压管总成(直)10-L2890-1SC-60°	2	
14	255031020013	Hydraulic hose assembly 10-L3180-1SC-60°	液压管总成(直)10-L3180-1SC-60°	2	
14	255031020014	Hydraulic hose assembly 10-L3630-1SC-60°	液压管总成(直)10-L3630-1SC-60°	2	
14	281227511003	Hydraulic hose assembly 10-L4300-1SC-60°	液压管总成(直)10-L4300-1SC-60°	2	
15	255031020004	Axle Φ20x70	带耳轴Φ20x70	1	
16	255031020007	Pulley Φ90x22	滑轮Φ90x22(单槽)	2	
17	255031010001	Pulley support welded 1	滑轮支架焊接1	1	
17	255031010002	Pulley support welded 2	滑轮支架焊接2	1	

门架(标准门架)-3.0T/Mast (standard mast)-3.0T

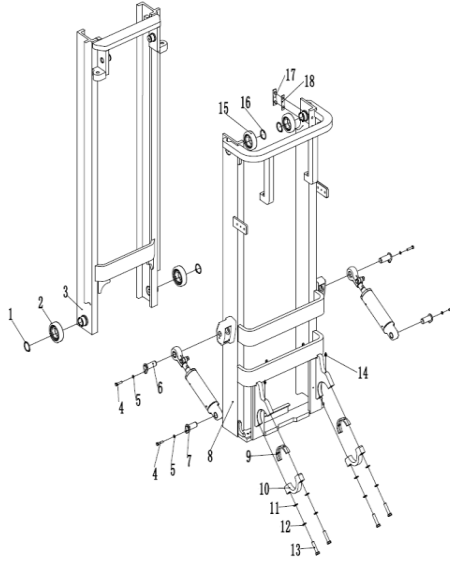

序号/NO	编码/SN	Name	名称	数量/QTY	备注/Remarks
1	910401300026	Circlip GB894.1-55	轴用弹性挡圈GB894.1-55	2	
2	940200300014	Roller φ119.2-range=59.5-64.5	复合滚轮 φ119.2-range=59.5-64.5	2	
3	256044012001	Mast 2000	内门架焊合2000	1	H=2000
	256044012002	Mast 2500	内门架焊合2500	1	H=2500
	256044012003	Mast 3000	内门架焊合3000	1	H=3000
	256044012004	Mast 3300	内门架焊合3300	1	H=3300
	256044012005	Mast 3500	内门架焊合3500	1	H=3500
	256044012006	Mast 3600	内门架焊合3600	1	H=3600
	256044012007	Mast 3700	内门架焊合3700	1	H=3700
	256044012008	Mast 4000	内门架焊合4000	1	H=4000
	256044012009	Mast 4300	内门架焊合4300	1	H=4300
	256044012010	Mast 4500	内门架焊合4500	1	H=4500
	256044012011	Mast 5000	内门架焊合5000	1	H=5000
	256044012012	Mast 5500	内门架焊合5500	1	H=5500
	256044012013	Mast 6000	内门架焊合6000	1	H=6000
4	910100300035	Bolt GB5783-M10x20-8.8	螺栓GB5783-M10x20-8.8	4	
5	910400100007	Washer GB97.1-10-200HV	平垫圈GB97.1-10-200HV	9	
6	255044010057	Axle φ30x82	带耳轴 φ30x82	2	
7	255044010057	Axle φ30x72	带耳轴 φ30x82	2	
8	256044011001	Mast 2000	外门架焊合2000	1	H=2000
	256044011002	Mast 2500	外门架焊合2500	1	H=2500
	256044011003	Mast 3000	外门架焊合3000	1	H=3000
	256044011004	Mast 3300	外门架焊合3300	1	H=3300
	256044011005	Mast 3500	外门架焊合3500	1	H=3500
	256044011006	Mast 3600	外门架焊合3600	1	H=3600
	256044011007	Mast 3700	外门架焊合3700	1	H=3700
	256044011008	Mast 4000	外门架焊合4000	1	H=4000
	256044011009	Mast 4300	外门架焊合4300	1	H=4300
	256044011010	Mast 4500	外门架焊合4500	1	H=4500
	256044011011	Mast 5000	外门架焊合5000	1	H=5000
256044011012	Mast 5500	外门架焊合5500	1	H=5500	
256044011013	Mast 6000	外门架焊合6000	1	H=6000	

门架(标准门架)-3.5T/Mast (standard mast)-3.5T

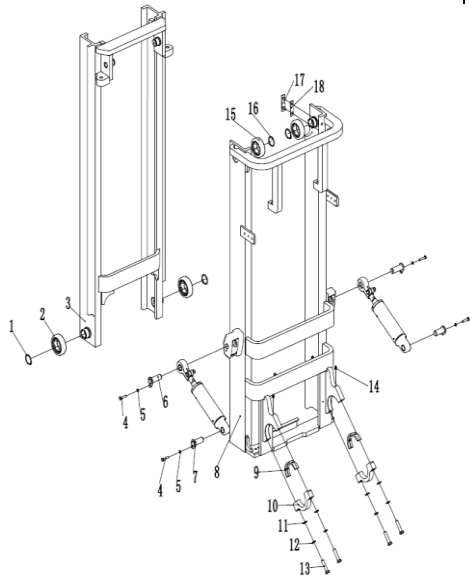

序号/NO	编码/SN	Name	名称	数量/QTY	备注/Remarks
1	910401300026	Circlip GB894.1-55	轴用弹性挡圈GB894.1-55	2	
2	940200300014	Roller φ119.2-range=59.5-64.5	复合滚轮 φ119.2-range=59.5-64.5	2	
3	256144012001	Mast 2000	内门架焊合2000	1	H=2000
	256144012002	Mast 2500	内门架焊合2500	1	H=2500
	256144012003	Mast 3000	内门架焊合3000	1	H=3000
	256144012004	Mast 3300	内门架焊合3300	1	H=3300
	256144012005	Mast 3500	内门架焊合3500	1	H=3500
	256144012006	Mast 3600	内门架焊合3600	1	H=3600
	256144012007	Mast 3700	内门架焊合3700	1	H=3700
	256144012008	Mast 4000	内门架焊合4000	1	H=4000
	256144012009	Mast 4300	内门架焊合4300	1	H=4300
	256144012010	Mast 4500	内门架焊合4500	1	H=4500
	256144012011	Mast 5000	内门架焊合5000	1	H=5000
	256144012012	Mast 5500	内门架焊合5500	1	H=5500
	256144012013	Mast 6000	内门架焊合6000	1	H=6000
4	910100300035	Bolt GB5783-M10x20-8.8	螺栓GB5783-M10x20-8.8	4	
5	910400100007	Washer GB97.1-10-200HV	平垫圈GB97.1-10-200HV	9	
6	255044010057	Axle φ30x82	带耳轴 φ30x82	2	
7	255044010057	Axle φ30x72	带耳轴 φ30x72	2	
8	256144011001	Mast 2000	外门架焊合2000	1	H=2000
	256144011002	Mast 2500	外门架焊合2500	1	H=2500
	256144011003	Mast 3000	外门架焊合3000	1	H=3000
	256144011004	Mast 3300	外门架焊合3300	1	H=3300
	256144011005	Mast 3500	外门架焊合3500	1	H=3500
	256144011006	Mast 3600	外门架焊合3600	1	H=3600
	256144011007	Mast 3700	外门架焊合3700	1	H=3700
	256144011008	Mast 4000	外门架焊合4000	1	H=4000
	256144011009	Mast 4300	外门架焊合4300	1	H=4300
	256144011010	Mast 4500	外门架焊合4500	1	H=4500
	256144011011	Mast 5000	外门架焊合5000	1	H=5000
256144011012	Mast 5500	外门架焊合5500	1	H=5500	
256144011013	Mast 6000	外门架焊合6000	1	H=6000	

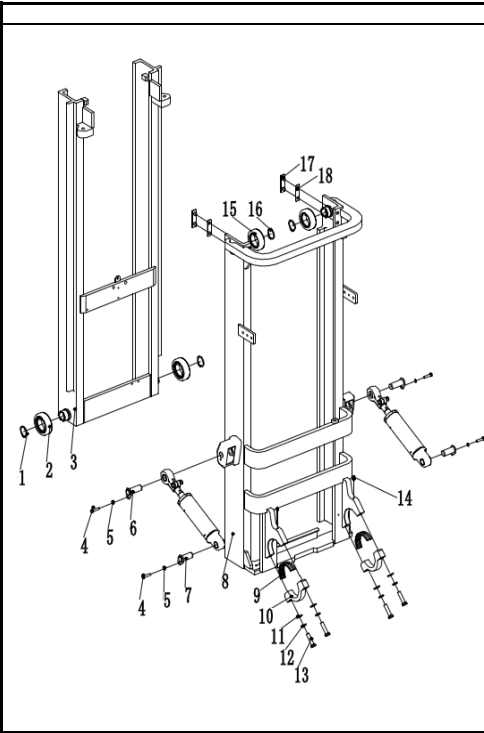

门架 (二级全自由) / Mast (two stage full free)						
序号/NO	编码/SN	Name	名称	数量/QTY	备注/Remarks	
1	910401300026	Circlip GB894.1-55	轴用弹性挡圈GB894.1-55	2		
2	940200300014	Roller φ119.2-range=59.5-64.5	复合滚轮 φ119.2-range=59.5-64.5	2		
3	255043510014	Mast 2000	外门架焊合2000	1	H=2000	
	255043510015	Mast 2500	外门架焊合2500	1	H=2500	
	255043510016	Mast 3000	外门架焊合3000	1	H=3000	
	255043510017	Mast 3300	外门架焊合3300	1	H=3300	
	255043510018	Mast 3500	外门架焊合3500	1	H=3500	
	255043510019	Mast 3600	外门架焊合3600	1	H=3600	
	255043510020	Mast3700	外门架焊合3700	1	H=3700	
	255043510021	Mast 4000	外门架焊合4000	1	H=4000	
	255043510022	Mast 4300	外门架焊合4300	1	H=4300	
	255043510023	Mast 4500	外门架焊合4500	1	H=4500	
	255043510024	Mast 5000	外门架焊合5000	1	H=5000	
	255043510025	Mast 5500	外门架焊合5500	1	H=5500	
	255043510026	Mast 6000	外门架焊合6000	1	H=6000	
4	910100300035	Bolt GB5783-M10x20-8.8	螺栓GB5783-M10x20-8.8	4		
5	910400100007	Washer GB97.1-10-200HV	平垫圈GB97.1-10-200HV	9		
6	255044010057	Axle φ30x82	带耳轴 φ30x82	2		
7	255044010057	Axle φ30x72	带耳轴 φ30x72	2		
8	255043510027	Mast 2000	内门架焊合2000	1	H=2000	
	255043510028	Mast 2500	内门架焊合2500	1	H=2500	
	255043510029	Mast 3000	内门架焊合3000	1	H=3000	
	255043510030	Mast 3300	内门架焊合3300	1	H=3300	
	255043510031	Mast 3500	内门架焊合3500	1	H=3500	
	255043510032	Mast 3600	内门架焊合3600	1	H=3600	
	255043510033	Mast 3700	内门架焊合3700	1	H=3700	
	255043510034	Mast 4000	内门架焊合4000	1	H=4000	
	255043510035	Mast 4300	内门架焊合4300	1	H=4300	
	255043510036	Mast4500	内门架焊合4500	1	H=4500	
8	255043510037	Mast5000	内门架焊合5000	1	H=5000	
	255043510038	Mast5500	内门架焊合5500	1	H=5500	
	255043510039	Mast6000	内门架焊合6000	1	H=6000	

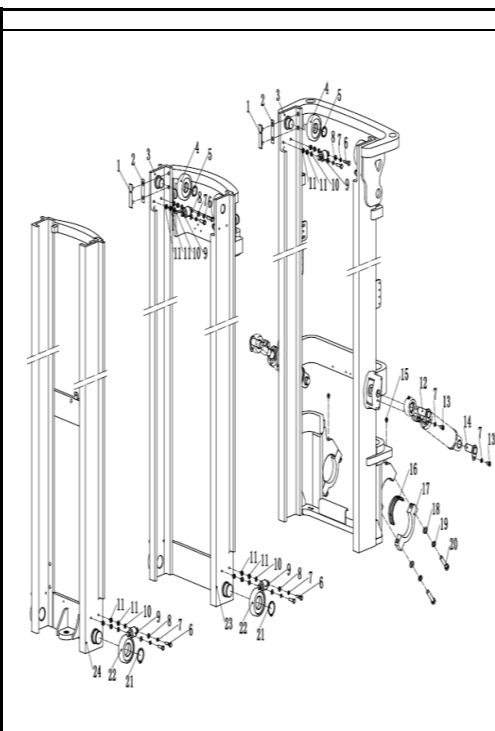

门架(三級全自由)/Mast (three stage full free)						
序号/NO	编码/SN	Name	名称	数量/QTY	备注/Remarks	
1	255044020131	Guide plate	导向板	4		
2	255044020125	Adjusting pad φ35xφ16x0.8	调整垫 φ35x φ16x0.8	4	选装/Optional	
	255044020126	Adjusting pad φ35xφ16x0.5	调整垫 φ35x φ16x0.5	4	选装/Optional	
	255044020127	Adjusting pad φ35xφ16x0.2	调整垫 φ35x φ16x0.2	4	选装/Optional	
3	255044510030	Mast 4000	外门架焊接4000	1	H=4000	
	255044510031	Mast 4300	外门架焊接4300	1	H=4300	
	255044510032	Mast 4500	外门架焊接4500	1	H=4500	
	255044510033	Mast 4800	外门架焊接4800	1	H=4800	
	255044510034	Mast 5000	外门架焊接5000	1	H=5000	
	255044510035	Mast 5500	外门架焊接5500	1	H=5500	
	255044510036	Mast 6000	外门架焊接6000	1	H=6000	
4	940200100012	Roller φ109.7xφ40x32	主滚轮φ109.7xφ40x32	4		
5	910401300026	Circlip GB894.1-55	轴用弹性挡圈GB894.1-55	4		
6	910100300039	Bolt GB5783-M10x40-8.8	螺栓GB5783-M10x40-8.8	4		
7	910400500008	Washer GB93-12	弹簧垫圈GB93-12	6		
8	910400100007	Washer GB97.1-10-200HV	平垫圈GB97.1-10-200HV	8		
9	940200200005	Roller φ42-CD=68	侧滚轮φ42-CD=68	8		
10	255038020008	Adjusting pad	侧滚轮调整套	8		
11	255038020009	Adjusting pad	侧滚轮调整垫	8		
12	255044010057	Axle φ30x82	带耳轴φ30x82	2		
13	910100300035	Bolt GB5783-M10x20-8.8	螺栓GB5783-M10x20-8.8	4		
14	255044010057	Axle φ30x72	带耳轴φ30x82	2		
15	911200100004	Grease nipple JB7940.1-M10x1	油杯JB7940.1-M10x1	2		
16	255044020006	Bearing bush	轴瓦	2		
17	255044020005	Bearing cover	支座盖	2		
18	910400500010	Washer GB93-16	弹簧垫圈GB93-16	4		
19	910100200016	Bolt GB5785-M16x1.5x70-8.8	螺栓GB5785-M16x1.5x70-8.8	4		
20	910400100010	Washer GB97.1-16-200HV	平垫圈GB97.1-16-200HV	4		
21	910401300026	Circlip GB894.1-55	轴用弹性挡圈GB894.1-55	2		
22	940200300014	Roller φ119.2-range=59.5-64.5	复合滚轮φ119.2-range=59.5-64.5	2		
23	255044510023	Mast 4000	中门架焊接4000	1	H=4000	
	255044510024	Mast 4300	中门架焊接4300	1	H=4300	

起升油缸(标准门架)-30T/Lifting cylinder(standard mast)-30T

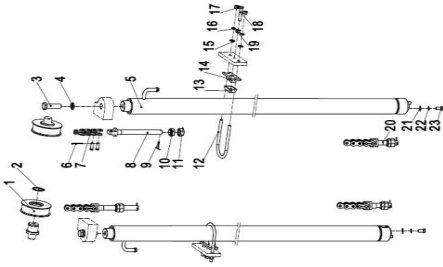
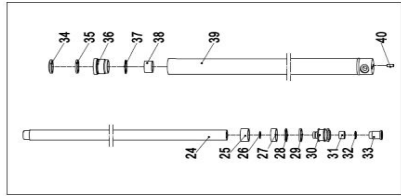

序号/NO	编码/SN	Name	名称	数量/QTY	备注/Remarks
1	940200500005	Chain wheel bearing780708K-φ110xφ40x27	链轮轴承780708K-φ110xφ40x27	2	
2	910401300020	Circlip GB894.1-40	轴用弹性挡圈GB894.1-40	2	
3	910400500010	Washer GB93-16	弹簧垫圈GB93-16	4	
4	910100400029	Bolt GB5786-M16x1.5x40-8.8	螺栓GB5786-M16x1.5x40-8.8	2	
5	256044016001	Cylinder Φ56xΦ45x995(H=2000)	油缸(H=2000)	2	包含/Inc. 24-41
	256044016002	Cylinder Φ56xΦ45x1245(H=2500)	油缸(H=2500)	2	
	256044016003	Cylinder Φ56xΦ45x1495(H=3000)	油缸(H=3000)	2	
	256044016004	Cylinder Φ56xΦ45x1645(H=3300)	油缸(H=3300)	2	
	256044016005	Cylinder Φ56xΦ45x1745(H=3500)	油缸(H=3500)	2	
	256044016006	Cylinder Φ56xΦ45x1825(H=3600)	油缸(H=3600)	2	
	256044016007	Cylinder Φ56xΦ45x1845(H=3700)	油缸(H=3700)	2	
	256044016008	Cylinder Φ56xΦ45x1995(H=4000)	油缸(H=4000)	2	
	256044016009	Cylinder Φ56xΦ45x2120(H=4300)	油缸(H=4300)	2	
	256044016010	Cylinder Φ56xΦ45x2245(H=4500)	油缸(H=4500)	2	
	256044016011	Cylinder Φ56xΦ45x2495(H=5000)	油缸(H=5000)	2	
	256044016012	Cylinder Φ56xΦ45x2745(H=5500)	油缸(H=5500)	2	
	256044016013	Cylinder Φ56xΦ45x2995(H=6000)	油缸(H=6000)	2	
6	▲	Split pin 2.5x40	开口销2.5x40	2	
7	▲	LH1623 chain	LH1623板式链	2	
8	▲	Joint	长端接头	2	
9	▲	Split pin 3.2x30	开口销3.2x30	2	
10	▲	Nut M18x1.5	球面螺母M18x1.5	2	
11	▲	Nut M18x1.5	螺母M18x1.5	2	
12	255044020128	Fixing ring	U形螺栓Φ68	2	
13	255044020129	Rubber bushing	防护罩	2	
14	255044020130	Fixing seat	固定座(油缸)	2	
15	910400100007	Washer GB97.1-16-200HV	平垫圈GB97.1-16-200HV	4	
16	910400500007	Washer GB93-10	弹簧垫圈GB93-10	4	
17	910300200002	Nut GB6171-M10x1.25-10	螺母GB6171-M10x1.25-10	4	
18	910100300041	Bolt GB5783-M10x50-8.8	螺栓GB5783-M10x50-8.8	2	
19	910300100007	Nut GB6170-M10-10	螺母GB6170-M10-10	2	
20	▲	Joint	短端接头	2	

起升油缸(标准门架)-30T/Lifting cylinder(standard mast)-30T

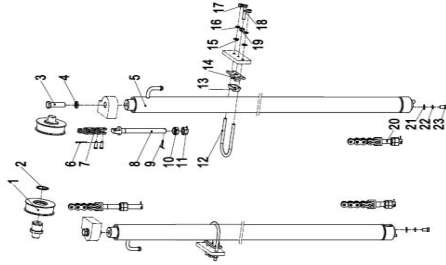
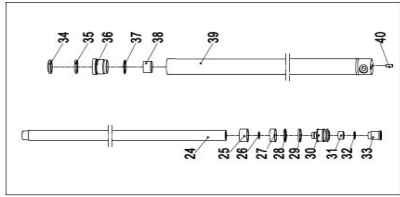

序号/NO	编码/SN	Name	名称	数量/QTY	备注/Remarks
21	910400100008	Washer GB97.1-12-200HV	平垫圈GB97.1-12-200HV	2	
22	910400500008	Washer GB93-12	弹簧垫圈GB93-12	2	
23	9101004000009	Bolt GB5786-M12x1.25x25-8.8	螺栓GB5786-M12x1.25x25-8.8	2	
24	▲	Piston rod	活塞杆	1	
25	▲	Adjusting bushing 40.5x49xL2	调整套40.5x49xL2	1	
26	▲	Circlip	钢丝挡圈	1	
27	▲	Bearing 50x20x2.5	支承环56x20x2.5	1	
28	▲	Catch 50x40x3	挡片56x45x3	1	
29	▲	Seal ring 50x40x6	孔用密封圈	1	
30	▲	Piston rod	活塞	1	
31	▲	Copper bushing	铜套	1	
32	▲	Circlip	钢丝挡圈	1	
33	▲	Buffering ring	缓冲环	1	
34	▲	Dust ringDKB40x52x7/10	防尘圈	1	
35	▲	Seal ring 40x50x6	轴用密封圈	1	
36	▲	Guide sleeve	导向套	1	
37	▲	O ring 49.7x2.4	O型密封圈	1	
38	▲	Bearing 4030	钢背轴承4530	1	
39	▲	Cylinder	缸体	1	
40	▲	Dowel pin	圆柱销D10x26	1	
41	255098510001	Seal kits(standard mast lifting cylinder)	密封件修理包(标准门架起升缸)	2	包含/Inc. 27.29.34.35.37
A	255043510139	Lifting chain LH1623-77	起升链条LH1623-79	2	H=3000
	255044510133	Lifting chain LH1623-57	起升链条LH1623-59	2	H=2000
	255043510085	Lifting chain LH1623-67	起升链条LH1623-69	2	H=2500
	255044510140	Lifting chain LH1623-83	起升链条LH1623-85	2	H=3300
	255043510088	Lifting chain LH1623-87	起升链条LH1623-89	2	H=3500
	255044010107	Lifting chain LH1623-89	起升链条LH1623-91	2	H=3600
	253543510066	Lifting chain LH1623-91	起升链条LH1623-93	2	H=3700
	255043510107	Lifting chain LH1623-99	起升链条LH1623-101	2	H=4000
	253544510027	Lifting chain LH1623-105	起升链条LH1623-107	2	H=4300
	255043510090	Lifting chain LH1623-109	起升链条LH1623-111	2	H=4500
	253511010064	Lifting chain LH1623-121	起升链条LH1623-121	2	H=5000
	256044014001	Lifting chain LH1623-131	起升链条LH1623-133	2	H=5500
	256044014002	Lifting chain LH1623-141	起升链条LH1623-143	2	H=6000

起升油缸 (标准门架)-35T/Lifting cylinder (standard mast)-35T

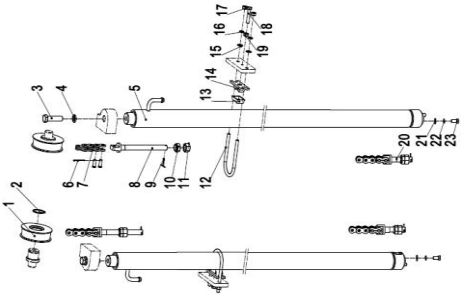
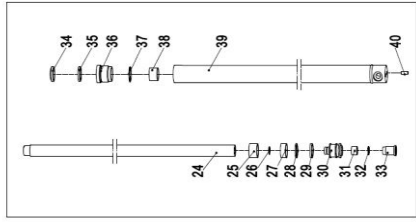

序号/NO	编码/SN	Name	名称	数量/QTY	备注/Remarks
1	940200500005	Chain wheel bearing 780708K-φ110xφ40x27	链轮轴承780708K-φ110xφ40x27	2	
2	910401300020	Circlip GB894.1-40	轴用弹性挡圈GB894.1-40	2	
3	910400500010	Washer GB93-16	弹簧垫圈GB93-16	4	
4	910100400029	Bolt GB5786-M16x1.5x40-8.8	螺栓GB5786-M16x1.5x40-8.8	2	
5	256044016001	Cylinder Φ56xΦ45x995(H=2000)	油缸(H=2000)	2	包含/Inc. 24-41
	256044016002	Cylinder Φ56xΦ45x1245(H=2500)	油缸(H=2500)	2	
	256044016003	Cylinder Φ56xΦ45x1495(H=3000)	油缸(H=3000)	2	
	256044016004	Cylinder Φ56xΦ45x1645(H=3300)	油缸(H=3300)	2	
	256044016005	Cylinder Φ56xΦ45x1745(H=3500)	油缸(H=3500)	2	
	256044016006	Cylinder Φ56xΦ45x1825(H=3600)	油缸(H=3600)	2	
	256044016007	Cylinder Φ56xΦ45x1845(H=3700)	油缸(H=3700)	2	
	256044016008	Cylinder Φ56xΦ45x1995(H=4000)	油缸(H=4000)	2	
	256044016009	Cylinder Φ56xΦ45x2120(H=4300)	油缸(H=4300)	2	
	256044016010	Cylinder Φ56xΦ45x2245(H=4500)	油缸(H=4500)	2	
	256044016011	Cylinder Φ56xΦ45x2495(H=5000)	油缸(H=5000)	2	
	256044016012	Cylinder Φ56xΦ45x2745(H=5500)	油缸(H=5500)	2	
	256044016013	Cylinder Φ56xΦ45x2995(H=6000)	油缸(H=6000)	2	
6	▲	Split pin 2x20	开口销2x20	2	
7	▲	LH1634 chain	LH1634板式链	2	
8	▲	Joint	长端接头	2	
9	▲	Split pin 3.2x40	开口销3.2x40	2	
10	▲	Nut M20x1.5	球面螺母M20x1.5	2	
11	▲	Nut M20x1.5	螺母M20x1.5	2	
12	255044020128	Fixing ring	U形螺栓Φ68	2	
13	255044020129	Rubber bushing	防护罩	2	
14	255044020130	Fixing seat	固定座(油缸)	2	
15	910400100007	Washer GB97.1-16-200HV	平垫圈GB97.1-16-200HV	4	
16	910400500007	Washer GB93-10	弹簧垫圈GB93-10	4	
17	910300200002	Nut GB6171-M10x1.25-10	螺母GB6171-M10x1.25-10	4	
18	910100300041	Bolt GB5783-M10x50-8.8	螺栓GB5783-M10x50-8.8	2T	
19	910300100007	Nut GB6170-M10-10	螺母GB6170-M10-10	2	
20	35480-06003	Joint	短端接头	2	

起升油缸 (标准门架)-35T/Lifting cylinder (standard mast)-35T

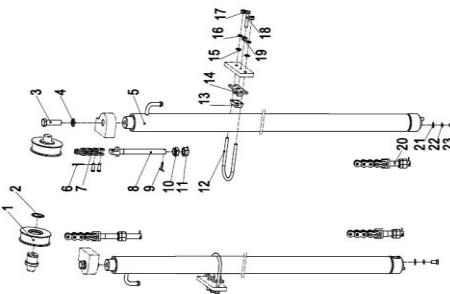
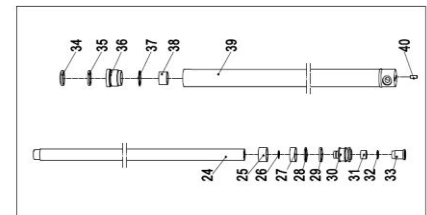

序号/NO	编码/SN	Name	名称	数量/QTY	备注/Remarks
21	910400100008	Washer GB97.1-12-200HV	平垫圈GB97.1-12-200HV	2	
22	910400500008	Washer GB93-12	弹簧垫圈GB93-12	2	
23	9101004000009	Bolt GB5786-M12x1.25x25-8.8	螺栓GB5786-M12x1.25x25-8.8	2	
24	▲	Piston rod	活塞杆	1	
25	▲	Adjusting bushing 40.5x49xL2	调整套40.5x49xL2	1	
26	▲	Circlip	钢丝挡圈	1	
27	▲	Bearing 50x20x2.5	支承环56x20x2.5	1	
28	▲	Catch 50x40x3	挡片56x45x3	1	
29	▲	Seal ring 50x40x6	孔用密封圈	1	
30	▲	Piston rod	活塞	1	
31	▲	Copper bushing	铜套	1	
32	▲	Circlip	钢丝挡圈	1	
33	▲	Buffering ring	缓冲环	1	
34	▲	Dust ringDKB40x52x7/10	防尘圈	1	
35	▲	Seal ring 40x50x6	轴用密封圈	1	
36	▲	Guide sleeve	导向套	1	
37	▲	O ring 49.7x2.4	O型密封圈	1	
38	▲	Bearing 4030	钢背轴承4530	1	
39	▲	Cylinder	缸体	1	
40	▲	Dowel pin	圆柱销D10x26	1	
41	256098510001	Seal kits(standard mast lifting cylinder)	密封件修理包(标准门架起升缸)	2	包含/Inc. 27.29.34.35.37
A	263044010042	Lifting chain LH1634-79	起升链条LH1634-79	2	H=3000
	256144014001	Lifting chain LH1634-59	起升链条LH1634-59	2	H=2000
	263044510025	Lifting chain LH1634-69	起升链条LH1634-69	2	H=2500
	263043510065	Lifting chain LH1634-85	起升链条LH1634-85	2	H=3300
	263044510006	Lifting chain LH1634-89	起升链条LH1634-89	2	H=3500
	254044010057	Lifting chain LH1634-91	起升链条LH1634-91	2	H=3600
	254011010058	Lifting chain LH1634-93	起升链条LH1634-93	2	H=3700
	254044510027	Lifting chain LH1634-101	起升链条LH1634-101	2	H=4000
	263044510008	Lifting chain LH1634-107	起升链条LH1634-107	2	H=4300
	254044010061	Lifting chain LH1634-111	起升链条LH1634-111	2	H=4500
	256144014002	Lifting chain LH1634-121	起升链条LH1634-121	2	H=5000
	256144014003	Lifting chain LH1634-133	起升链条LH1634-133	2	H=5500
256144014004	Lifting chain LH1634-143	起升链条LH1634-143	2	H=6000	

短升降油缸(二级全自由)/Short lifting cylinder (two stage full free)

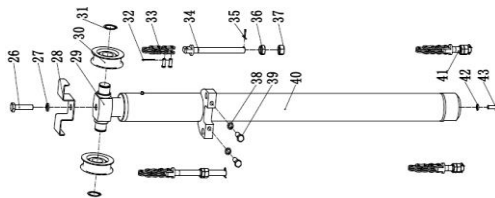
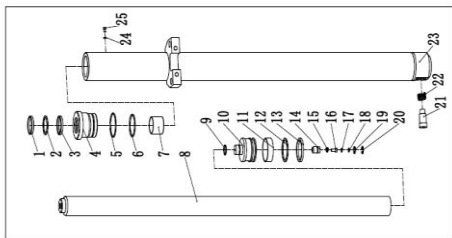

序号/NO	编码/SN	Name	名称	数量/QTY	备注/Remarks
A	255043510079	Lifting chain LH1623-37	起升链条LH1623-37	2	H=2000
	255043510080	Lifting chain LH1623-47	起升链条LH1623-47	2	H=2500
	255044010059	Lifting chain LH1623-55	起升链条LH1623-55	2	H=3000
	255044510134	Lifting chain LH1623-61	起升链条LH1623-61	2	H=3300
	255044010103	Lifting chain LH1623-65	起升链条LH1623-65	2	H=3500
	255044510135	Lifting chain LH1623-59	起升链条LH1623-59	2	H=3600
		Lifting chain LH1623-59	起升链条LH1623-59		H=3700
	255044510046	Lifting chain LH1623-67	起升链条LH1623-67	2	H=4000
	255044510047	Lifting chain LH1623-73	起升链条LH1623-73	2	H=4300
	255043510139	Lifting chain LH1623-77	起升链条LH1623-77	2	H=4500
	255044010106	Lifting chain LH1623-87	起升链条LH1623-87	2	H=5000
	255043510107	Lifting chain LH1623-99	起升链条LH1623-99	2	H=5500
	255043510106	Lifting chain LH1623-109	起升链条LH1623-109	2	H=6000
1	▲	Dust ring 60x74x8/11	防尘圈	1	
2	▲	Catch 60x70x3	挡片60×70×3	1	
3	▲	Seal ring 60x70x6	轴用密封圈	1	
4	▲	Guide sleeve	导向套	1	
5	▲	O ring 84.4x3.1	O型密封圈	1	
6	▲	O ring 77.5x3.55	O型密封圈	1	
7	▲	Bearing 6035	钢背轴承6035	1	
8	▲	Piston rod	活塞杆	1	
9	▲	Circlip	钢丝挡圈	1	
10	▲	Piston assembly	活塞总成	1	
11	▲	Back up ring D85x20x2.5	支承环D85x20x2.5	1	
12	▲	Circlip 85x70x3	挡圈85x70x3	1	
13	▲	Seal ring 85x70x9	密封圈85x70x9	1	
14	▲	Valve bushing	阀套	1	
15	▲	Spring	弹簧	1	
16	▲	Valve plug	阀芯	1	
17	▲	Catch	挡片	1	
18	▲	O ring D15.8x2.4	O型密封圈	1	
19	▲	Circlip φ12	挡圈φ12	1	

短升降油缸(二级全自由)/Short lifting cylinder (two stage full free)

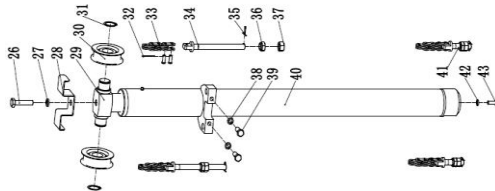
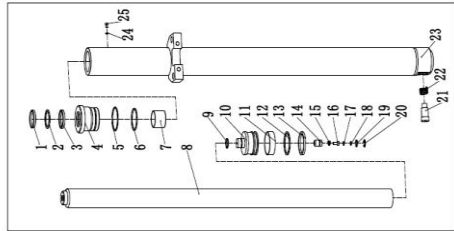

序号/NO	编码/SN	Name	名称	数量/QTY	备注/Remarks
20	▲	Circlip φ22	挡圈 φ22	1	
21	▲	Slide valve	滑阀	1	
22	▲	Spring	弹簧	1	
23	▲	Cylinder	缸体	1	
24	▲	Spacer	垫片	1	
25	▲	Screw M5x5	螺钉M5x5	1	
26	910200200123	Screw GB70.1-M16x50-8.8	螺钉GB70.1-M16x50-8.8	1	
27	910400500010	Washer GB93-16	弹簧垫圈GB93-16	1	
28	255043520020	Chain plate	挡链板	1	
29	255043520006	Cylinder head	缸头	1	
30	940200500005	Chain wheel bearing 780708K-φ110xφ40x27	链轮轴承780708K-φ110xφ40x27	1	
31	910401300020	Circlip GB894.1-40	轴用弹性挡圈GB894.1-40	1	
32	▲	Split pin 2.5x40	开口销2.5x40	2	
33	▲	LH1623 chain	LH1623板式链	2	
34	▲	Joint	长端接头	2	
35	▲	Split pin 3.2x30	开口销3.2x30	2	
36	▲	Nut M18x1.5	球面螺母M18x1.5	2	
37	▲	Nut M18x1.5	螺母M18x1.5	2	
38	910400500009	Washer GB93-14	弹簧垫圈GB93-14	2	
39	910100400022	Bolt GB5786-M14x1.5x40-8.8	螺栓GB5786-M14x1.5x40-8.8	2	
40	255043510068	Cylinder (M)φ85xφ60x772(H=3000)	油缸(M)(H=3000)	1	包含/Inc. No.1-25
	255043510066	Cylinder (M)φ85xφ60x522(H=2000)	油缸(M)(H=2000)	1	
	255043510067	Cylinder (M)φ85xφ60x647(H=2500)	油缸(M)(H=2500)	1	
	255043510069	Cylinder (M)φ85xφ60x847(H=3300)	油缸(M)(H=3300)	1	
	255043510070	Cylinder (M)φ85xφ60x897(H=3500)	油缸(M)(H=3500)	1	
	255043510071	Cylinder (M)φ85xφ60x922(H=3600)	油缸(M)(H=3600)	1	
	255043510072	Cylinder (M)φ85xφ60x947(H=3700)	油缸(M)(H=3700)	1	
	255043510073	Cylinder (M)φ85xφ60x1047(H=4000)	油缸(M)(H=4000)	1	
	255043510074	Cylinder (M)φ85xφ60x1122(H=4300)	油缸(M)(H=4300)	1	
	255043510075	Cylinder (M)φ85xφ60x1172(H=4500)	油缸(M)(H=4500)	1	
	255043510076	Cylinder (M)φ85xφ60x1297(H=5000)	油缸(M)(H=5000)	1	

起升油缸(二级全自由)/Lifting cylinder(two stage full free)

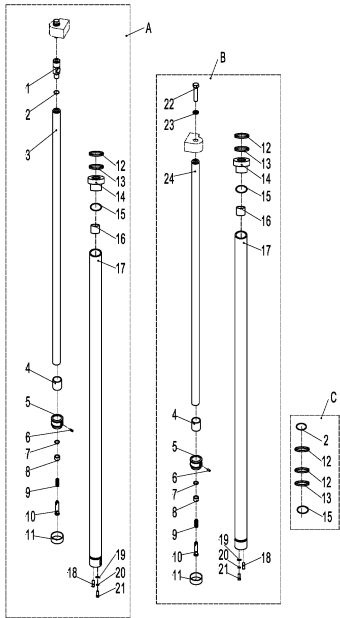

序号/NO	编码/SN	Name	名称	数量/QTY	备注/Remarks
A	255043510040	Cylinder (L)Φ50xΦ40x940(H=2000)	油缸(L)(H=2000)	1	包含/Inc. 1-21
	255043510041	Cylinder (L)Φ50xΦ40x1190(H=2500)	油缸(L)(H=2500)	1	
	255043510042	Cylinder (L)Φ50xΦ40x1440(H=3000)	油缸(L)(H=3000)	1	
	255043510043	Cylinder (L)Φ50xΦ40x1590(H=3300)	油缸(L)(H=3300)	1	
	255043510044	Cylinder (L)Φ50xΦ40x1690(H=3500)	油缸(L)(H=3500)	1	
	255043510045	Cylinder (L)Φ50xΦ40x1740(H=3600)	油缸(L)(H=3600)	1	
	255043510046	Cylinder (L)Φ50xΦ40x1790(H=3700)	油缸(L)(H=3700)	1	
	255043510047	Cylinder (L)Φ50xΦ40x1890(H=4000)	油缸(L)(H=4000)	1	
	255043510048	Cylinder (L)Φ50xΦ40x2040(H=4300)	油缸(L)(H=4300)	1	
	255043510049	Cylinder (L)Φ50xΦ40x2140(H=4500)	油缸(L)(H=4500)	1	
	255043510050	Cylinder (L)Φ50xΦ40x2390(H=5000)	油缸(L)(H=5000)	1	
	255043510051	Cylinder (L)Φ50xΦ40x2590(H=5500)	油缸(L)(H=5500)	1	
	255043510052	Cylinder (L)Φ50xΦ40x2840(H=6000)	油缸(L)(H=6000)	1	
	B	255043510053	Cylinder (R)Φ50xΦ40x940(H=2000)	油缸(R)(H=2000)	
255043510054		Cylinder (R)Φ50xΦ40x1190(H=2500)	油缸(R)(H=2500)	1	
255043510055		Cylinder (R)Φ50xΦ40x1440(H=3000)	油缸(R)(H=3000)	1	
255043510056		Cylinder (R)Φ50xΦ40x1590(H=3300)	油缸(R)(H=3300)	1	
255043510057		Cylinder (R)Φ50xΦ40x1690(H=3500)	油缸(R)(H=3500)	1	
255043510058		Cylinder (R)Φ50xΦ40x1740(H=3600)	油缸(R)(H=3600)	1	
255043510059		Cylinder (R)Φ50xΦ40x1790(H=3700)	油缸(R)(H=3700)	1	
255043510060		Cylinder (R)Φ50xΦ40x1890(H=4000)	油缸(R)(H=4000)	1	
255043510061		Cylinder (R)Φ50xΦ40x2040(H=4300)	油缸(R)(H=4300)	1	
255043510062		Cylinder (R)Φ50xΦ40x2140(H=4500)	油缸(R)(H=4500)	1	
255043510063		Cylinder (R)Φ50xΦ40x2390(H=5000)	油缸(R)(H=5000)	1	
255043510064		Cylinder (R)Φ50xΦ40x2590(H=5500)	油缸(R)(H=5500)	1	
255043510065	Cylinder (R)Φ50xΦ40x2840(H=6000)	油缸(R)(H=6000)	1		
C	255098510002	Seal kits (two stage full free lifting cylinder)	密封件修理包(二级全自由起升缸)	2	包含/Inc. 2, 12, 13, 15
1	▲	Connecting rod	左连接杆	1	
2	▲	O ring 26x2.4	O型密封圈	1	
3	▲	Piston rod assembly	左柱塞杆总成	1	
4	▲	Adjusting bushing	调整套	2	
5	▲	Piston	缓冲活塞	2	

短升降油缸 (三级全自由) / Short lifting cylinder (three stage full free)

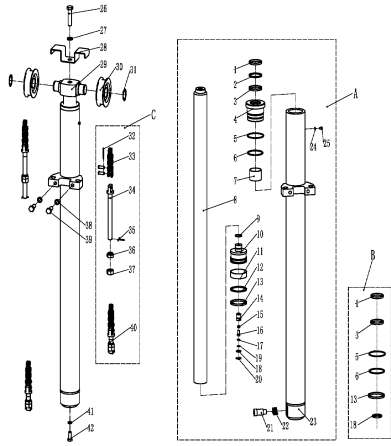

序号/NO	编码/SN	Name	名称	数量/QTY	备注/Remarks
A	255044510100	Cylinder (M)Φ75xΦ50x622(H=3600)	油缸(M)(H=3600)	1	包含/Inc. 1-25
A	255044510050	Cylinder (M)Φ75xΦ50x685(H=4000)	油缸(M)(H=4000)	1	
A	255044510051	Cylinder (M)Φ75xΦ50x748(H=4300)	油缸(M)(H=4300)	1	
A	255044510052	Cylinder (M)Φ75xΦ50x772(H=4500)	油缸(M)(H=4500)	1	
A	255044510053	Cylinder (M)Φ75xΦ50x822(H=4800)	油缸(M)(H=4800)	1	
A	255044510054	Cylinder (M)Φ75xΦ50x879(H=5000)	油缸(M)(H=5000)	1	
A	255044510055	Cylinder (M)Φ75xΦ50x995(H=5500)	油缸(M)(H=5500)	1	
A	255044510056	Cylinder (M)Φ75xΦ50x1112(H=6000)	油缸(M)(H=6000)	1	
A	255044510103	Cylinder (M)Φ75xΦ50x1229(H=6500)	油缸(M)(H=6500)	1	
B	255098510005	Seal kits (three stage full free lifting cylinder)	密封件修理包 (三级全自由中间缸)	1	
C	255044510124	Lifting chain LH1623-45	起升链条LH1623-45	2	H=3600
C	255044510044	Lifting chain LH1623-47	起升链条LH1623-47	2	H=4000
C	255044510045	Lifting chain LH1623-53	起升链条LH1623-53	2	H=4300
C	255044010060	Lifting chain LH1623-55	起升链条LH1623-55	2	H=4500
C	255044510133	Lifting chain LH1623-59	起升链条LH1623-59	2	H=4800
C	255044510134	Lifting chain LH1623-63	起升链条LH1623-63	2	H=5000
C	255044510135	Lifting chain LH1623-61	起升链条LH1623-61	2	H=5500
C	255044510136	Lifting chain LH1623-71	起升链条LH1623-71	2	H=6000
C	255044510137	Lifting chain LH1623-81	起升链条LH1623-81	2	H=6500
1	▲	Dust ring 50x58x6.5	防尘圈	1	
2	▲	Catch 50x60x3	挡片50×60×3	1	
3	▲	Seal ring 50x60x6	轴用密封圈	1	
4	▲	Glide sleeve	导向套	1	
5	▲	O ring 74.4x3.1	O型密封圈	1	
6	▲	O ring 69x3.55	O型密封圈	1	
7	▲	Bearing5040	钢背轴承5040	1	
8	▲	Piston rod	活塞杆	1	
9	▲	Circlip	钢丝挡圈	1	
10	▲	Piston assembly	活塞总成	1	
11	▲	Support ring 75x20x2.5	支承环75x20x2.5	1	
12	▲	Support ring 75x65x3	支承环75x65x3	1	
13	▲	Seal ring 75x65x6	孔用密封圈	1	

短升降油缸 (三级全自由) / Short lifting cylinder (three stage full free)

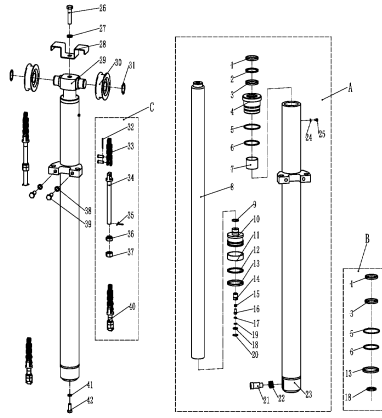

序号/NO	编码/SN	Name	名称	数量/QTY	备注/Remarks
14	▲	Valve cover	阀套	1	
15	▲	Spring	弹簧	1	
16	▲	Valve plug	阀芯	1	
17	▲	Catch	挡片	1	
18	▲	O ring D20x2.4	O型密封圈	1	
19	▲	Circlip 12	孔用弹性挡圈12	1	
20	▲	Circlip 22	孔用弹性挡圈22	1	
21	▲	Slide valve	滑阀	1	
22	▲	Spring 2.3x15x48.5	弹簧 2.3x15x48.5	1	
23	▲	Cylinder	缸体	1	
24	▲	Spacer	垫片	1	
25	▲	Screw M5x5	内六角圆柱头螺钉M5x5	1	
26	910100100071	Bolt GB5782-M16x50-8.8	螺栓GB5782-M16x50-8.8	1	
27	910400500010	Washer GB93-16	弹簧垫圈GB93-16	1	
28	255043520020	Block chain plate	挡链板	1	
29	255043520006	Cylinder head	缸头	1	
30	940200500001	Chain wheel bearing 780708K-φ110xφ40x27	链轮轴承780708K-φ110xφ40x27	2	
31	910401300020	Circlip GB894.1-40	轴用弹性挡圈GB894.1-40	2	
32	▲	split pin 2.5x40	开口销 2.5x40	2	
33	▲	LH1623 chain	LH1623板式链	2	
34	▲	Joint	长端接头	2	
35	▲	Split pin 3.2x30	开口销 3.2x30	2	
36	▲	Nut M18x1.5	球面螺母M18x1.5	2	
37	▲	Nut M18x1.5	螺母M18x1.5	2	
38	910400500009	Washer GB93-14	弹簧垫圈GB93-14	2	
39	910100400022	Bolt GB5786-M14x1.5x40-8.8	螺栓GB5786-M14x1.5x40-8.8	2	
41	▲	Joint	短端接头	2	
42	910400500008	Spring Washer GB93-12	弹簧垫圈GB93-12	1	
43	910100400009	Bolt GB5786-M12x1.25x25-8.8	螺栓GB5786-M12x1.25x25-8.8	1	

起升油缸 (三级全自由) / Lifting cylinder (three stage full free)

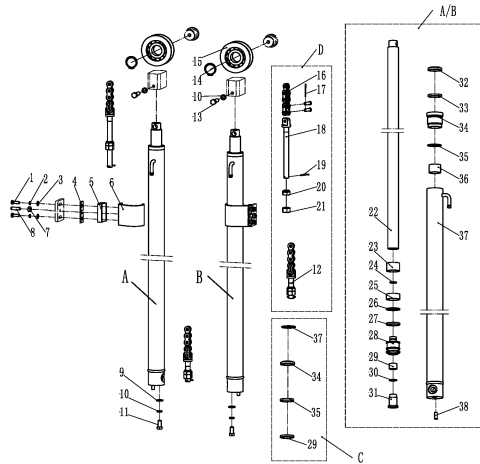

序号/NO	编码/SN	Name	名称	数量/QTY	备注/Remarks
A	255044510104	Cylinder (L)Φ50xΦ40x1174	油缸(L)(H=3600)	1	包含/Inc. 24-40
A	255044510004	Cylinder (L)Φ50xΦ40x1312	油缸(L)(H=4000)	1	
A	255044510005	Cylinder (L)Φ50xΦ40x1424	油缸(L)(H=4300)	1	
A	255044510006	Cylinder (L)Φ50xΦ40x1474	油缸(L)(H=4500)	1	
A	255044510007	Cylinder (L)Φ50xΦ40x1574	油缸(L)(H=4800)	1	
A	255044510008	Cylinder (L)Φ50xΦ40x1617	油缸(L)(H=5000)	1	
A	255044510009	Cylinder (L)Φ50xΦ40x1751	油缸(L)(H=5500)	1	
A	255044510010	Cylinder (L)Φ50xΦ40x1884	油缸(L)(H=6000)	1	
A	255044510107	Cylinder (L)Φ50xΦ40x2017	油缸(L)(H=6500)	1	
B	255044510108	Cylinder (R)Φ50xΦ40x1174	油缸(R)(H=3600)	1	
B	255044510011	CyRinder (R)Φ50xΦ40x1312	油缸(R)(H=4000)	1	
B	255044510012	CyRinder (R)Φ50xΦ40x1424	油缸(R)(H=4300)	1	
B	255044510013	CyRinder (R)Φ50xΦ40x1474	油缸(R)(H=4500)	1	
B	255044510014	CyRinder (R)Φ50xΦ40x1574	油缸(R)(H=4800)	1	
B	255044510015	CyRinder (R)Φ50xΦ40x1617	油缸(R)(H=5000)	1	
B	255044510016	CyRinder (R)Φ50xΦ40x1751	油缸(R)(H=5500)	1	
B	255044510017	CyRinder (R)Φ50xΦ40x1884	油缸(R)(H=6000)	1	
B	255044510111	Cylinder (R)Φ50xΦ40x2017	油缸(R)(H=6500)	1	
C	255098510003	Seal kits(three stage full free lifting cylinder)	密封件修理包(三级全自由起升缸)	2	包含Inc. 29, 34, 35, 37
D	255044510134	Lifting chainLH1623-63	起升链条LH1623-63	2	H=3600
D	255044510046	Lifting chainLH1623-69	起升链条LH1623-69	2	H=4000
D	255044510138	Lifting chainLH1623-73	起升链条LH1623-73	2	H=4300
D	255044510047	Lifting chainLH1623-75	起升链条LH1623-75	2	H=4500
D	255043510139	Lifting chainLH1623-79	起升链条LH1623-79	2	H=4800
D	255044510140	Lifting chainLH1623-85	起升链条LH1623-85	2	H=5000
D	255044510048	Lifting chainLH1623-95	起升链条LH1623-95	2	H=5500
D	255044510049	Lifting chainLH1623-103	起升链条LH1623-103	2	H=6000
D	255044510125	Lifting chainLH1623-113	起升链条LH1623-113	2	H=6500
1	910100300023	Bolt GB5783-M8x25-8.8	螺栓GB5783-M8x25-8.8	4	
2	910400500006	Washer GB93-8	弹簧垫圈GB93-8	4	
3	910400100006	Washer GB97.1-8-200HV	平垫圈GB97.1-8-200HV	4	
4	255044520099	Rubber pad	橡胶垫	2	
5	255044520100	Support block	支撑块	2	
6	255044520098	Blendboard	弯板	2	
8	910300100007	Screw M10x35-8.8	螺钉M10x35-8.8	2	
9	941100100003	Nut GB6170-M10-10	螺母GB6170-M10-10	2	

起升油缸 (三级全自由) / Lifting cylinder (three stage full free)

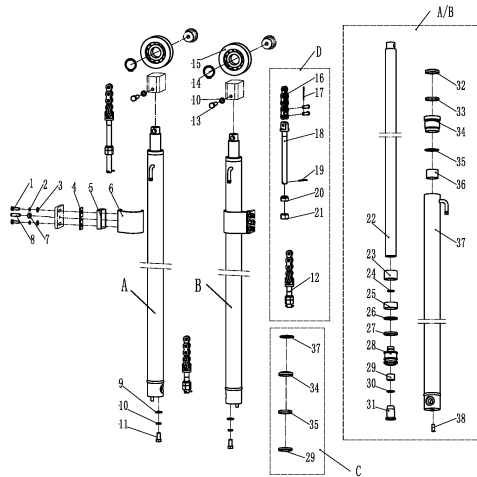

序号/NO	编码/SN	Name	名称	数量/QTY	备注/Remarks
10	910400100008	Washer GB97.1-12-200HV	平垫圈GB97.1-12-200HV	2	
11	910400500008	Washer GB93-12	弹簧垫圈GB93-12	4	
12	9101004000009	Bolt GB5786-M12x1.25x25-8.8	螺栓GB5786-M12x1.25x25-8.8	2	
13	▲	Joint	短端接头	2	
15	910100300053	Bolt GB5783-M12x45-8.8	螺栓GB5783-M12x45-8.8	2	
16	910401300020	Circlip GB894.1-40	轴用弹性挡圈GB894.1-40	2	
17	940200500005	Chain wheel bearing 780708K-φ110xφ40x27	链轮轴承780708K-φ110xφ40x27	2	
18	▲	LH1623 chain	LH1623板式链	2	
19	▲	Split pin 2.5x40	开口销2.5x40	2	
20	▲	Joint	长端接头	2	
21	▲	Split pin 3.2x30	开口销3.2x30	2	
22	▲	Nut M18x1.5	球面螺母M18x1.5	2	
23	▲	Nut M18x1.5	螺母M18x1.5	2	
24	▲	Piston rod	活塞杆	1	
25	▲	Adjusting bushing 40.5x49xL2	调整套40.5x49xL2	1	
26	▲	Circlip φ24x2	钢丝挡圈 φ24x2	1	
27	▲	Bearing 50x20x2.5	支承50x20x2.5	1	
28	▲	Catch 50x40x3	挡片50x40x3	1	
29	▲	Seal ring 50x40x6	孔用密封圈	1	
30	▲	Piston	活塞	1	
31	▲	Copper bushing	铜套	1	
32	▲	Circlip φ26.5x2	钢丝挡圈 φ26.5x2	1	
33	▲	Buffer ring	缓冲环	1	
34	▲	Dust ring DKB40x52x7/10	防尘圈	1	
35	▲	Seal ring 40x50x6	轴用密封圈	1	
36	▲	Guide bushing	导向套	1	
37	▲	O seal ring 49.7x2.4	O型密封圈	1	
38	▲	Bearing 4030	钢背轴承4030	1	
39	▲	Cylinder	缸体	1	
40	▲	Dowel pin D10x26	圆柱销D10x26	1	

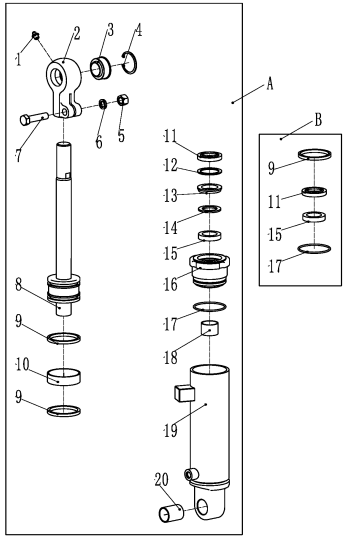

倾斜油缸/Tilted cylinder

序号/NO	编码/SN	Name	名称	数量/QTY	备注/Remarks
A	256120510001	Tilted cylinder (6/10)	左倾斜油缸 (6/10)	1	Hs3700,Left
A	256120510002	Tilted cylinder (6/6)	左倾斜油缸 (6/6)	1	3700 < Hs5000,Left
A	256120510003	Tilted cylinder (3/6)	左倾斜油缸 (3/6)	1	5000 < H,Left
A	256120510005	Tilted cylinder (6/10)	右倾斜油缸 (6/10)	1	Hs3700,Right
A	256120510006	Tilted cylinder (6/6)	右倾斜油缸 (6/6)	1	3700 < Hs5000,Right
A	256120510007	Tilted cylinder (3/6)	右倾斜油缸 (3/6)	1	5000 < H,Right
B	256198510006	Seal kits (tilted cylinder)	密封件修理包(倾斜缸)	2	
1	▲	Grease mouth Z1/8	直通式滑脂嘴Z1/8	2	
2	▲	Earring	耳环	2	
3	▲	Bearing GE30ES	关节轴承GE30ES	2	
4	▲	Circlip 47	挡圈47	2	
5	▲	NutM14	螺母M14	2	
6	▲	Washer14	垫圈14	2	
7	▲	BoltM14x55	螺栓M14x55	2	
8	▲	Piston body assembly	活塞体总成	2	
9	▲	Yx seal ring D80x70x6	U型密封圈	2	
10	▲	Support ring D80x75x20	支承环80x75x20	2	
11	▲	Dust ring 35x47x7	防尘圈	2	
12	▲	Circlip	挡圈	2	
13	▲	Circlip	挡圈	2	
14	▲	Catch 35x45x3	挡片35x45x3	2	
15	▲	Useal ring 35x45x10	U型密封圈	2	
16	▲	Guide sleeve	导向套	2	
17	▲	O seal ring 80x3.1	O型密封圈	2	
18	▲	Bearing 3530	钢背轴承3530	2	
19	▲	Cylinder barrel assembly	缸筒总成	2	
20	▲	Bearing 3038	钢背轴承3038	2	

电器系统/Electric system

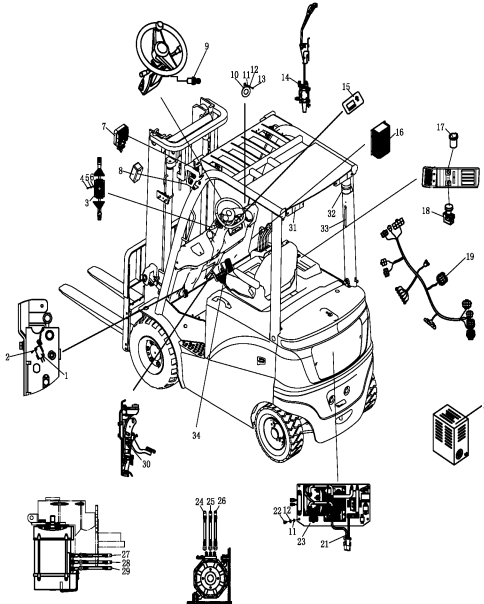

序号/NO	编码/SN	Name	名称	数量/QTY	备注/Remarks
1	920200300009	Micro switch	微动开关	1	驻车制动/Parking brake
2	910400100003	Washer GB97.1-4-200HV	平垫圈GB97.1-4-200HV	2	
3	920200800013	Combination switch JK361B-1003	组合开关	1	
4	910200500038	Screw GB818-M5x12-4.8	螺钉GB818-M5x12-4.8	4	
5	910400500004	Washer GB93-5	弹簧垫圈GB93-5	8	
6	910400100004	Washer GB97.1-5-200HV	平垫圈GB97.1-5-200HV	8	
7	922000100066	Light FLDD-9Z-FX	灯FLDD-9Z-FX	2	前大灯/headlamps
8	922000100052	Light FLDJ-QXD-001	灯FLDJ-QXD-001	2	前转向灯/front turn signal lamp
9	920200200031	Key switch	钥匙开关(一档双路)	1	
10	920500100001	Horn 125-DC24V	喇叭125-DC24V	1	
11	910400100005	Washer GB97.1-6-200HV	平垫圈GB97.1-6-200HV	1	
12	910400500005	Washer GB93-6	弹簧垫圈GB93-6	1	
13	910200500051	Screw GB818-M6x12-4.8	螺钉GB818-M6x12-4.8	1	
14	920200300004	Micro switch	微动开关	3	multiway valve
15	921100100011	Indicator 3501-12-80V	仪表3501	1	Curtis-SE
	921100100045	Indicator IDD	仪表IDD	1	Inmotion
	921100100063	Indicator 3401T-12-96V	仪表3401T-12-96V		Curtis-F
16	921900100002	Transducer DC80V 24V	转换器DC80V转24V	1	
17	921900100004	Transducer DC24V 5V	转换器DC24V转5V	4	
18	920200100020	Emergency stop switch LAY39-01MJ-RC	急停开关LAY39-01MJ-RC	1	
19	255033010001	Body wiring harness (Curtis-4P25N)	车身线束(Curtis-4P25N)	1	Curtis-SE
	256033010013	Body wiring harness (Inmotion-4P30N)	车身线束(Inmotion-4P30N)	1	Inmotion
	255033010018	Truck body harness(Curtis-F-4P25N)	车身线束(Curtis-F系列-4P25N)	1	Curtis-F
20	921000200085	Charger SN80V80A(Asia Chinese)	充电器SN80V80A(亚中)	1	560Ah
	921000200086	Charger SN80V80A(Asia English)	充电器SN80V80A(亚英)	1	560Ah
	921000200089	Charger SN80V80A(Australian)	充电器SN80V80A(澳)	1	560Ah
	921000200090	Charger SN80V80A(America)	充电器SN80V80A(美)	1	560Ah
	921000200171	Charger SN80V65A(Asia Chinese)	充电器SN80V65A(亚中)	1	500Ah
	921000200172	Charger SN80V65A(Asia English)	充电器SN80V65A(亚英)	1	500Ah
	921000200175	Charger SN80V65A(Australian)	充电器SN80V65A(澳)	1	500Ah
	921000200176	Charger SN80V65A(America)	充电器SN80V65A(美)	2	500Ah
21	256033010009	Cable	电源线缆	1	
22	910200200058	ScrewGB70.1-M8x25-8.8	螺钉GB70.1-M8x25-8.8	1	
23	256033010002	Electric control(Curtis-4P30N)	电控组件(Curtis-4P30N)	1	Curtis-SE
	256033010011	Electric control(Inmotion-4P30N)	电控组件(Inmotion-4P30N)	1	Inmotion
	256033010014	Electric control(Curtis-F-4P30N)	电控组件(Curtis-F系列-4P30N)	1	Curtis-F
24	256033010006	Cable-U2-35-6-8-1350	线缆-U2-50-8-8-1350	1	
25	256033010007	Cable-V2-35-6-8-1300	线缆-V2-35-6-8-1300	1	
26	256033010008	Cable-W2-35-6-8-1250	线缆-W2-35-6-8-1250	1	
27	256033010003	Cable-U1-35-6-8-3100	线缆-U1-50-8-8-3250	1	
28	256033010004	Cable-V1-35-6-8-3050	线缆-V1-35-6-8-3200	1	
29	256033010005	Cable-W1-35-6-8-3000	线缆-W1-35-6-8-3150	1	
30	920201000002	Foot pedal	脚踏开关	1	
31	922000100003	Light PDL-LXHW-2	灯PDL-LXHW-2	2	后组合灯/ Rear combination lamp
32	922000100004	Light PDL-LXJD-01Y	灯PDL-LXJD-01Y	1	警示灯/Warning lights
33	255033510001	Rear lever switch	后把手开关	1	
34	921700100005	Accelerator	加速器PZ3-532-133	1	Curtis
	921700100015	Accelerator	加速器JCH2-5L	1	Inmotion

标牌安装(中文)

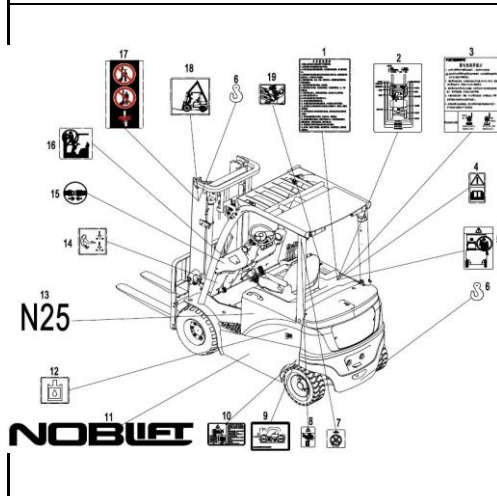

序号/NO	编码/SN	Name	名称	数量/QTY	备注/Remarks
A	2560985147501		标贴总成	1	
	2561985147501		标贴总成	1	
1	255047020003		叉车使用须知	1	
2	255047020016		润滑图表	1	
3	255047020007		蓄电池保养提示	1	
4	941200300011		提示标贴	1	
5	255047020013		禁止座人	1	
6	255047020011		吊装标贴	3	
7	255047020008		禁止起吊标识	2	
8	941200100027		挤手标贴	2	
9	255047020002		轮胎气压标识	2	
10	255047020017		轮胎拆卸标识	2	
11	255047020022		诺力标志	2	
12	255047020004		液压油标贴	1	
13	256047020007		产品型号标识	2	FE4P30N
	256147020007		产品型号标识	2	FE4P35N
14	255047020001		脚刹标贴	1	
15	255047020012		安全带标贴	1	
16	255047020009		禁止攀爬	1	
17	941200100004		安全标贴	2	
18	255047020019		整车吊装	2	
19	255047020006		电池箱盖开启标贴	1	

标牌安装(英文)/Labels		序号/NO	编码/SN	Name	名称	数量/QTY	备注/Remarks
	A	2560985147502	English labeling assembly	标贴总成	1		
		2561985147502	English labeling assembly	标贴总成	1		
	1	255047020007	Battery maintenance	蓄电池保养提示	1		
	2	941200300011	Warning label	提示标贴	1		
	3	255047020013	"No passengers" decal	禁止座人	1		
	4	255047020011	Crane hook label	吊装标贴	3		
	5	255047020008	No crane label	禁止起吊标识	2		
	6	941200100027	Squeeze hand stick	挤手标贴	2		
	7	255047020002	Tyre pressure label	轮胎气压标识	2		
	8	255047020022	Noblelift logo	诺力标志	2		
	9	255047020006	Supporting point label	支撑点标识	1		
	10	255047020004	Hydraulic oil sticker	液压油标贴	1		
	11	256047020007	Product model sticker	产品型号标识	2	FE4P30N	
		256147020007	Product model sticker	产品型号标识	2	FE4P35N	
	12	255047020001	Foot brake sticker	脚刹标贴	1		
	13	255047020012	Safety belt sticker	安全带标贴	1		
14	255047020009	No climbing	禁止攀爬	1			
15	941200100004	Safety label	安全标贴	2			
16	255047020006	Battery cover open sticker	电池箱盖开启标贴	1			

数据铭牌(英文)/Data nameplate

序号/NO	编码/SN	Name	名称	数量/QTY	备注/Remarks
1	255047520002	Nameplate	铭牌	1	
2	910500600002	Rivet GB827-3x10	铆钉GB827-3x10	4	
3	255047520005	Lose weight sticker with sidesway	带侧移减重标贴	1	
4	256047520003	Load capacity diagram	负荷曲线图	1	FE4P30N
	256147520003	Load capacity diagram	负荷曲线图	1	FE4P35N

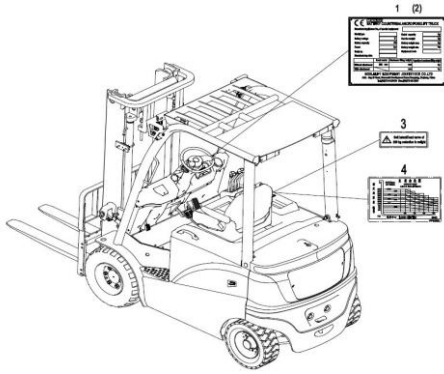

锂电池及附配重/Lithium Cell

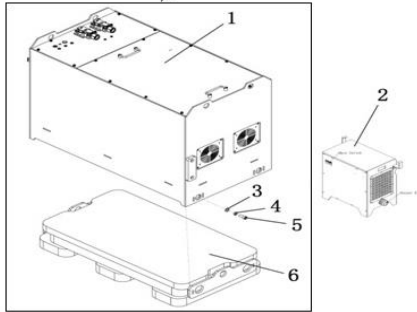

序号/NO	编码/SN	Name	名称	数量/QTY	备注/Remarks
A	256337013101		赣锂76.8V277GF2国际30N	1	选装
	256337013102		赣锂76.8V412GF2国际30N	1	选装
	256337013103		赣锂76.8V554GF2国际30N	1	选装
1	256337013104		赣锂76.8V277GF2加热国际30N	1	选装
	256337013105		赣锂76.8V412GF2加热国际30N	1	选装
	256337013106		赣锂76.8V554GF2加热国际30N	1	选装
2	256336512117	Lithium Charger ADY80V150A(380V 50/60Hz)	锂电充电器 ADY80V150A(380V 50/60Hz)	1	300Ah
	256336512118	Lithium Charger ADY80V150A(400V 50/60Hz)	锂电充电器 ADY80V150A(400V 50/60Hz)	1	300Ah
	256336512119	Lithium Charger ADY80V150A(415V 50/60Hz)	锂电充电器 ADY80V150A(415V 50/60Hz)	1	300Ah
	256336512120	Lithium Charger ADY80V150A(420-520V 50/60Hz)	锂电充电器 ADY80V150A(420-520V 50/60Hz)	1	300Ah
	256336512107	Lithium Charger ADY80V200A(380V 50/60Hz)	锂电充电器 ADY80V200A(380V 50/60Hz)	1	300Ah
	256336512108	Lithium Charger ADY80V200A(400V 50/60Hz)	锂电充电器 ADY80V200A(400V 50/60Hz)	1	400/500Ah
	256336512109	Lithium Charger ADY80V200A(415V 50/60Hz)	锂电充电器 ADY80V200A(415V 50/60Hz)	1	400/500Ah
	256336512110	Lithium Charger ADY80V200A(420-520V 50/60Hz)	锂电充电器 ADY80V200A(420-520V 50/60Hz)	1	400/500Ah
3	910400200005	Washer GB96.1-12-200HV	大垫圈GB96.1-12-200HV	4	
4	910400500008	Washer GB93-12	弹簧垫圈GB93-12	4	
5	910200200097	Screw GB70.1-M12x25-8.8	螺钉GB70.1-M12x25-8.8	4	
6	256323012001	Secondary weight	附配重	1	

